

PCT

WORLD INTELLECTUAL PROPERTY ORGANIZATION  
International Bureau



INTERNATIONAL APPLICATION PUBLISHED UNDER THE PATENT COOPERATION TREATY (PCT)

(51) International Patent Classification <sup>7</sup> : A61K 41/00	A2	(11) International Publication Number: WO 00/41726
		(43) International Publication Date: 20 July 2000 (20.07.00)
(21) International Application Number: PCT/US00/00852 (22) International Filing Date: 14 January 2000 (14.01.00) (30) Priority Data: 60/116,235 15 January 1999 (15.01.99) US (71) Applicant (for all designated States except US): LIGHT SCIENCES, LTD. [US/US]; No.E-5, 1065 12th Avenue N.W., Issaquah, WA 98027 (US). (72) Inventor; and (75) Inventor/Applicant (for US only): CHEN, James [US/US]; 2011 - 87th Place N.E., Bellevue, WA 98004 (US). (74) Agents: MAYS, Thomas, D. et al.; Morrison & Foerster LLP, 2000 Pennsylvania Avenue N.W., Washington, DC 20006-1888 (US).	(81) Designated States: AL, AM, AT, AU, AZ, BA, BB, BG, BR, BY, CA, CH, CN, CR, CU, CZ, DE, DK, DM, EE, ES, FI, GB, GD, GE, GH, GM, HR, HU, ID, IL, IN, IS, JP, KE, KG, KP, KR, KZ, LC, LK, LR, LS, LT, LU, LV, MA, MD, MG, MK, MN, MW, MX, NO, NZ, PL, PT, RO, RU, SD, SE, SG, SI, SK, SL, TJ, TM, TR, TT, UA, UG, US, UZ, VN, YU, ZA, ZW, ARIPO patent (GH, GM, KE, LS, MW, SD, SL, SZ, TZ, UG, ZW), Eurasian patent (AM, AZ, BY, KG, KZ, MD, RU, TJ, TM), European patent (AT, BE, CH, CY, DE, DK, ES, FI, FR, GB, GR, IE, IT, LU, MC, NL, PT, SE), OAPI patent (BF, BJ, CF, CG, CI, CM, GA, GN, GW, ML, MR, NE, SN, TD, TG).  Published Without international search report and to be republished upon receipt of that report.	

(54) Title: NONINVASIVE VASCULAR THERAPY

(57) Abstract

The present invention is drawn to methods and compounds for transcutaneous photodynamic therapy ("PDT") of a target tissue or compositions in a mammalian subject, which includes administering to the subject a therapeutically effective amount of a photosensitizing agent or a photosensitizing agent delivery system or a prodrug, where the photosensitizing agent or photosensitizing agent delivery system or prodrug selectively binds to the target tissue; and irradiating at least a portion of the subject with light at a wavelength absorbed by the photosensitizing agent or if prodrug, by a prodrug product thereof, where the light is provided by a light source, and where the irradiation is at low fluence rate that results in the activation of the photosensitizing agent or prodrug product. These methods of transcutaneous PDT are useful in the treatment of specifically selected target tissues, such as: vascular endothelial tissue; abnormal vascular wall of tumors; tumors of the head and neck; tumors of the gastrointestinal tract; tumors of the liver; tumors of the esopharyngeal; tumors of the lung; lymphoid tissue; lesions in the vascular system; bone marrow and tissue related to autoimmune disease.

*FOR THE PURPOSES OF INFORMATION ONLY*

Codes used to identify States party to the PCT on the front pages of pamphlets publishing international applications under the PCT.

AL	Albania	ES	Spain	LS	Lesotho	SI	Slovenia
AM	Armenia	FI	Finland	LT	Lithuania	SK	Slovakia
AT	Austria	FR	France	LU	Luxembourg	SN	Senegal
AU	Australia	GA	Gabon	LV	Latvia	SZ	Swaziland
AZ	Azerbaijan	GB	United Kingdom	MC	Monaco	TD	Chad
BA	Bosnia and Herzegovina	GE	Georgia	MD	Republic of Moldova	TG	Togo
BB	Barbados	GH	Ghana	MG	Madagascar	TJ	Tajikistan
BE	Belgium	GN	Guinea	MK	The former Yugoslav Republic of Macedonia	TM	Turkmenistan
BF	Burkina Faso	GR	Greece			TR	Turkey
BG	Bulgaria	HU	Hungary	ML	Mali	TT	Trinidad and Tobago
BJ	Benin	IE	Ireland	MN	Mongolia	UA	Ukraine
BR	Brazil	IL	Israel	MR	Mauritania	UG	Uganda
BY	Belarus	IS	Iceland	MW	Malawi	US	United States of America
CA	Canada	IT	Italy	MX	Mexico	UZ	Uzbekistan
CF	Central African Republic	JP	Japan	NE	Niger	VN	Viet Nam
CG	Congo	KE	Kenya	NL	Netherlands	YU	Yugoslavia
CH	Switzerland	KG	Kyrgyzstan	NO	Norway	ZW	Zimbabwe
CI	Côte d'Ivoire	KP	Democratic People's Republic of Korea	NZ	New Zealand		
CM	Cameroon			PL	Poland		
CN	China	KR	Republic of Korea	PT	Portugal		
CU	Cuba	KZ	Kazakstan	RO	Romania		
CZ	Czech Republic	LC	Saint Lucia	RU	Russian Federation		
DE	Germany	LI	Liechtenstein	SD	Sudan		
DK	Denmark	LK	Sri Lanka	SE	Sweden		
EE	Estonia	LR	Liberia	SG	Singapore		

## NONINVASIVE VASCULAR THERAPY

### TECHNICAL FIELD OF THE INVENTION

This invention relates generally to the field of medicine and  
5 pharmacotherapeutics with photosensitizing agents or other energy activated agents.  
Specifically, this invention relates to methods, compounds, compositions and kits  
useful for site specific delivery to a lesion target site of a therapeutically effective  
amount of a photosensitizing agent that is activated by a relatively low fluence rate of  
light over a prolonged period of time. This invention further relates to the use of  
10 either an external or internal light source effective in providing transcutaneous  
photodynamic therapy as a treatment modality for atherosclerotic lesions and  
restenotic lesions in vivo.

### BACKGROUND OF THE INVENTION

15 One form of energy activated therapy is photodynamic therapy (PDT). PDT  
has been applied to the vascular system to treat atherosclerotic lesions and restenotic  
lesions in vivo.

PDT is performed by first administering a photosensitive compound  
systemically or topically, followed by illumination of the treatment site at a  
20 wavelength or waveband which closely matches the absorption spectra of the  
photosensitizer. In doing so, singlet oxygen and other reactive species are generated  
leading to a number of biological effects resulting in cytotoxicity. The depth and  
volume of the cytotoxic effect in tissue depends on the complex interactions of light  
penetration in tissue, the photosensitizer concentration and cellular location, and  
25 availability of molecular oxygen.

Vascular lesions are typically treated by light delivered from within the vessel  
by a fiberoptic probe as described by Mackie *et al* (Lasers in Surgery and Medicine  
11:535-544 (Wiley-Liss, Inc. 1991). Since light is delivered from within the lumen of  
the vessel, the vessel by necessity must be punctured in order to introduce the optical  
30 fiber. Puncture of an arterial vessel is associated with various medical risks including,  
downstream embolization from intravascular dislodgement of plaque or other debris;  
bleeding of the puncture site at the skin or vessel; heparinization may cause bleeding  
or other side effects; intimal flap from passage of the optical fiber causing

downstream infarction; repeat procedures pose increased total risk; infection from the optical fiber; thrombosis of the treated vessel; aneurysm formation; and perforation of the vessel wall. Furthermore, invasive PDT has other disadvantages such as inability to treat small vessel disease where the vessel(s) cannot be treated because the vessel diameter is too small and where it is unsafe to subject the patient to an invasive procedure which may increase risk of complications especially where infection and bleeding disorders pre-exist.

A large number of PDT light sources and methods of use have been described. However, reports describing the sources and effects of transcutaneous light delivery for PDT purposes are more limited. It has generally been accepted that the ability of a light source external to the body to cause clinically useful cytotoxicity is limited in depth to a range of 1-2 cm or less depending on the photosensitizer. Treatment of superficial tumors in this manner may be associated with inadvertent skin damage due to accumulation of the photosensitizer in the skin which is a property of all systemically administered sensitizers in clinical use. For example, clinically useful porphyrins such as Photophrin® (QLT, Ltd. brand of sodium porfimer) are associated with photosensitivity lasting up to 6 weeks. Purlytin®, which is a purpurin and Foscan® which is a chlorin sensitize the skin for several weeks. Indeed, efforts have been made to develop photoprotectants to reduce skin photosensitivity (see: Dillon *et al.*, *Photochemistry and Photobiology*, 48(2): 235-238, 1988; and Sigdestad *et al.*, *British J. of Cancer*, 74:S89-S92, 1996). In fact, PDT protocols involving systemic administration of photosensitizer require that the patient avoid sunlight and bright indoor light to reduce the chance of skin phototoxic reactions.

Recently, it has been claimed that with a sufficiently intense laser external light source causing two-photon absorption by a photosensitizer, it is theoretically possible to cause a very limited volume of cytotoxicity transcutaneously at greater depths. However, no clinical studies exist to support this contention. One would expect that the passage of an intense beam of light through the skin would lead to the same risk of injury to non-target tissues, such as skin and subcutaneous tissue, if used in conjunction with a systemically administered photosensitizer.

For example, one PDT modality discloses the use of an intense laser source to activate drug within a precisely defined boundary (see: Fisher *et al.*, "Method for improved selectivity in photo-activation of molecular agents", U.S. Pat. No.

5,829,448). The two-photon methodology requires a high power laser for drug activation with a highly collimated beam that requires a high degree of spatial control. For a large tumor this treatment is not practical since the beam would have to be swept across the skin surface in some sort of set, repeatable pattern over time. Patient or organ movement would be a problem, because the beam could become misaligned. Non-target tissue or skin and subcutaneous tissue photosensitivity is not addressed in the literature available. Any sensitizer in the path of the beam would be activated and cause unwanted collateral tissue damage. The present disclosure is a one-photon method and therefore teaches away from the two-photon method. Further, the present invention teaches and enables the prolonged exposure at a lower fluence rate, which promotes the protection of non-target tissue or skin and subcutaneous normal tissue and reduces collateral tissue damage.

Other modalities have employed the use of low total fluence of PDT delivered over a short time period to avoid skin photoactivation and the use of drug administration timing methods to enable destruction of small tumors in animals (see: U.S. Patent 5,705,518 (Richter *et al.*). However, the present disclosure teaches away from this method in order to enable large total fluence PDT, but at a lower fluence rate, which enables the treatment of larger tumor volumes. Richter *et al.* further fails to teach or disclose the suggestion of a targeting scheme as presently disclosed.

In the event that the target lesion lies below an intact cutaneous layer, the main drawbacks of all transcutaneous illumination methods, whether they be external laser or external nonlaser light sources, are: 1) the risk of damage to non-target tissues, such as the more superficial cutaneous and subcutaneous tissues overlying the target lesion, 2) limitation of treatment volume, and 3) limitation of treatment depth. Damage to normal tissue between the light source and the target occurs due to the uptake of photosensitizer by the skin and other tissues overlying the lesion with resultant unwanted photoactivation in these tissues. The consequences of inadvertent skin damage caused by transcutaneous light delivery to a subcutaneous lesion may include severe pain, serious infection, and fistula formation. The limited volume of a target lesion that can be clinically treated and the limitations of the light penetration below the skin surface in turn have limited clinical transcutaneous PDT to superficial, thin lesions.

Clearly, there would be significant advantage to a completely noninvasive form of PDT directed to subcutaneous vascular lesions which avoids the inadvertent activation of photosensitizer in skin and intervening tissues and also avoids damaging the vessel walls. To date, this feasibility has not been clinically demonstrated nor realized. Only in animal studies utilizing mice or other rodents with very thin cutaneous tissue layers, have very small superficial subcutaneous malignant tumors been treated. These *in vivo* studies do not enable or teach the safe application of transcutaneous light sources to treat atherosclerotic lesions and restenotic lesions in humans, however.

This invention further discloses the selective binding of the photosensitizing agent to specific target tissue antigens, such as those found on the surface of or within vascular lesions. This targeting scheme decreases the amount of sensitizing drug required for effective therapy, which in turn reduces the total fluence, and the fluence rate needed for effective photoactivation. For example, the highly specific uptake of photosensitizer in atherosclerotic vessels using the avidin-biotin system would result in reduced or no skin uptake enabling safe transcutaneous photoactivation. While there are several reports in the scientific literature of utilizing the specificity of the binding between biotin and streptavidin to target tumor cells, there are no reports utilizing this ligand-receptor binding pair aimed at vascular lesions nor in conjunction with prolonged PDT light exposure (see, for example: Savitsky *et al.*, *SPIE*, 3191: 343-353, 1997; and Ruebner *et al.*, *SPIE*, 2625: 328-332, 1996). In a non-PDT modality, the biotin-streptavidin ligand-receptor binding pair have also been reported used as tumor targeting conjugates with radionuclides (see: U.S. Pat. No. 5,630,996 (Reno *et al.*) and with monoclonal antibodies (see: Casalini *et al.*; *J. Nuclear Med.*, 38(9): 1378-1381, 1997) and U.S. Pat. No. 5,482,698 (Griffiths)).

Other ligand-receptor binding pairs have been used in PDT for targeting tumor antigens, but also fail to teach their use in conjunction with blood vessel targeting or treatment of atherosclerotic and restenotic lesions (see: for example, Mew *et al.*, *J. of Immunol.*, 130(3): 1473-1477, 1983)

A light source far less intense than a high powered laser is used (see: W.G. Fisher, *et al.*, *Photochemistry and Photobiology*, 66(2):141-155, 1997). The present disclosure teaches the unexpected use of a low power non-coherent light source



selectively binds to the target tissue which is an atherosclerotic plaque. This step is followed by irradiating at least a portion of the subject with light at a wavelength or waveband absorbed by the photosensitizing agent or if a prodrug, by a prodrug product thereof, where the light is provided by a light source, and where the irradiation is at a relatively low fluence rate that results in the activation of the photosensitizing agent or prodrug product. In this embodiment of the present invention, the photosensitizing agent or photosensitizing agent delivery system or prodrug is cleared from non-target tissues of the subject prior to irradiation.

One other embodiment of the present invention is drawn to a method for transcutaneous PDT of a target composition in a mammalian subject comprising: administering to the subject a therapeutically effective amount of a photosensitizing agent or a photosensitizing agent delivery system or a prodrug, where the photosensitizing agent or photosensitizing agent delivery system or prodrug selectively binds to the target composition. This step is followed by irradiating at least a portion of the subject with light at a wavelength or waveband absorbed by the photosensitizing agent or if a prodrug, by a prodrug product thereof, where said light is provided by a light source, and where the irradiation is at a relatively low fluence rate that results in the activation of the photosensitizing agent or said prodrug product. This embodiment contemplates that the photosensitizing agent or the photosensitizing agent delivery system or prodrug is cleared from non-target tissues of the subject prior to said irradiation. This embodiment also contemplates that light is delivered from a relatively low power noncoherent or coherent light source that is positioned in proximity to the diseased vessel, beneath the skin surface and external to the diseased blood vessel. Another preferred embodiment of the present invention is drawn to a method of transcutaneous PDT of a target tissue in a mammalian subject as described above, where the light source is entirely external to the patient's intact skin layer.

Another embodiment of this invention is drawn to a method of transcutaneous PDT, where the photosensitizing agent is conjugated to a ligand. One preferred embodiment of this invention contemplates a method of transcutaneous PDT, where the ligand is an antibody specific to thick or thin neointimas, arterial plaques, vascular smooth muscle cells and/or the abnormal extracellular matrix of the site to be treated. Other preferred embodiments include methods of transcutaneous PDT, where the ligand is a peptide or polymer specific to thick or thin neointimas, arterial plaques, ,



vascular smooth muscle cells and/or the abnormal extracellular matrix of the site to be treated..

A still further embodiment of the present invention is drawn to a method of transcutaneous PDT, where the photosensitizing agent is selected from the group consisting of: indocyanine green (ICG); methylene blue; toluidine blue;  
5 aminolevulinic acid (ALA); chlorin compounds; phthalocyanines; porphyrins; purpurins; texaphyrins; and any other agent that absorbs light in a range of 500 nm - 1100 nm. A preferred embodiment of this invention contemplates that the photosensitizing agent is indocyanine green (ICG).

10 One other embodiment of the present invention is drawn to a method of transcutaneous PDT, where the activation of the photosensitizing agent will likely occur within 30 minutes to 72 hours of irradiation, more preferably within 60 minutes to 48 hours of irradiation and most preferably within 3 hours to 24 hours of irradiation. Of course, clinical testing will be required to determine the optimal  
15 illumination time. In addition, it is contemplated that the total fluence delivered will preferably be between 30 Joules to 25,000 Joules, more preferably be between 100 Joules and 20,000 Joules, and most preferably be between 500 Joules to 10,000 Joules. Clinical testing will determine the optimal total fluence required to reduce the atheroma and undesirable tissue causing restenotic lesions.

20 A still further embodiment of this invention is drawn to a method for transcutaneous photodynamic therapy of target lesion in a mammalian subject comprising: administering to the subject a therapeutically effective amount of a first conjugate comprising a first member of a ligand-receptor binding pair conjugated to  
25 an antibody or antibody fragment, where the antibody or antibody fragment selectively binds to a target antigen found on thick or thin neointimas, arterial plaques, , vascular smooth muscle cells and/or the abnormal extracellular matrix of the site to be treated. This step is followed by administering to the subject a therapeutically effective amount of a second conjugate comprising a second member  
30 of the ligand-receptor binding pair conjugated to a photosensitizing agent or photosensitizing agent delivery system or prodrug, where the first member binds to the second member of the ligand-receptor binding pair. A subsequent step includes irradiating at least a portion of the subject with light at a wavelength or waveband absorbed by the photosensitizing agent or if prodrug, by the product thereof. This

embodiment further includes that the light is provided by a light source and that the irradiation is at a relatively low fluence rate that results in the activation of the photosensitizing agent or prodrug product.

5 Still further preferred embodiments of this invention are drawn to methods of transcutaneous PDT where the ligand-receptor binding pair is selected from the group consisting of: biotin-streptavidin; and antigen-antibody. A further preferred embodiment of the present invention is drawn to the presently disclosed methods where the antigens are vasculature antigens of the vascular lesion and the preferable ligand-receptor binding pair includes biotin-streptavidin. In this preferred  
10 embodiment, the activation of photosensitizer agents by a relatively low fluence rate light source over a prolonged period of time results in the destruction or reduction of the vascular lesion.

Another preferred embodiment contemplates a transcutaneous PDT method where the photosensitizing agent delivery system comprises a liposome delivery  
15 system consisting essentially of the photosensitizing agent.

Yet another embodiment of the present invention is drawn to a method for transcutaneous ultrasonic therapy of a target lesion in a mammalian subject comprising:

20 administering to the subject a therapeutically effective amount of an ultrasonic sensitizing agent or a ultrasonic sensitizing agent delivery system or a prodrug, where the ultrasonic sensitizing agent or ultrasonic sensitizing agent delivery system or prodrug selectively binds to the thick or thin neointimas, arterial plaques, s, vascular smooth muscle cells and/or the abnormal extracellular matrix of the site to be treated.. This step is followed by irradiating at least a portion of the subject with ultrasonic  
25 energy at a frequency that activates the ultrasonic sensitizing agent or if a prodrug, by a prodrug product thereof, where the ultrasonic energy is provided by an ultrasonic energy emitting source. This embodiment further provides that the ultrasonic therapy drug is cleared from non-target tissues of the subject prior to irradiation.

30 A preferred embodiment of this invention contemplates a method for transcutaneous ultrasonic therapy of a target tissue, where the target tissue is a lesion in the vascular system.

Other preferred embodiments of this invention contemplate that the ultrasonic energy emitting source is external to the patient's intact skin layer or is inserted

underneath the patient's intact skin layer, but is external to the blood vessel to be treated. An additional preferred embodiment of this invention provides that the ultrasonic sensitizing agent is conjugated to a ligand and more preferably, where the ligand is selected from the group consisting of: a target lesion specific antibody; a target lesion specific peptide and a target lesion specific polymer. Other preferred embodiments of the present invention contemplate that the ultrasonic sensitizing agent is selected from the group consisting of: indocyanine green (ICG); methylene blue; toluidine blue; aminolevulinic acid (ALA); chlorin compounds; phthalocyanines; porphyrins; purpurins; texaphyrins; and any other agent that absorbs light in a range of 500 nm -1100 nm. A preferred embodiment of this invention contemplates that the photosensitizing agent is indocyanine green (ICG).

Other embodiments of the present invention are drawn to the presently disclosed methods of transcutaneous PDT, where the light source is positioned in proximity to the target tissue of the subject and is selected from the group consisting of: an LED light source; an electroluminescent light source; an incandescent light source; a cold cathode fluorescent light source; organic polymer light source; and inorganic light source. A preferred embodiment includes the use of an LED light source.

Yet other embodiments of the presently disclosed methods are drawn to use of light of a wavelength that is from about 500 nm to about 1100 nm, preferably greater than about 650 nm and more preferably greater than about 700 nm. A preferable embodiment of the present method is drawn to the use of light that results in a single photon absorption mode by the photosensitizing agent.

Additional embodiments of the present invention include compositions of photosensitizer targeted delivery systems comprising: a photosensitizing agent; and a ligand that binds a receptor on the target tissue with specificity. Preferably, the photosensitizing agent of the targeted delivery system is conjugated to the ligand that binds a receptor on the target lesion with specificity. More preferably, the ligand comprises an antibody that binds to a receptor. Most preferably, the receptor is an antigen on thick or thin neointimas, arterial plaques, , vascular smooth muscle cells and/or the abnormal extracellular matrix of the site to be treated..

A further preferred embodiment of this invention contemplates that the

photosensitizing agent is selected from the group consisting of: indocyanine green (ICG); methylene blue; toluidine blue; aminolevulinic acid (ALA); chlorin compounds; phthalocyanines; porphyrins; purpurins; texaphyrins; and any other agent that absorbs light in a range of 500 nm -1100 nm.

5 Still another preferred embodiment of this invention contemplates that the ligand-receptor binding pair is selected from the group consisting of: biotin-streptavidin;; and antigen-antibody.

Yet another preferred embodiment contemplates that the photosensitizing agent comprises a prodrug.

10 Other embodiments of the presently disclosed invention contemplate methods for transcutaneous PDT to destroy a target cell in a mammalian subject comprising: administering to the subject a therapeutically effective amount of a photosensitizing agent or a photosensitizing agent delivery system or a prodrug, where the photosensitizing agent or photosensitizing agent delivery system or prodrug  
15 selectively binds to the target cell. This step is followed by irradiating at least a portion of the subject with light at a wavelength or waveband absorbed by the photosensitizing agent or if prodrug, by a prodrug product thereof, where the light is provided by a light source, and where the irradiation is at a relatively low fluence rate that results in the activation of the photosensitizing agent or prodrug product and the  
20 destruction of the target cell. This embodiment contemplates that the photosensitizing agent is cleared from non-target tissues of the subject prior to said irradiation.

#### BRIEF DESCRIPTION OF THE DRAWINGS

Figure 1A shows a diagram that demonstrates transcutaneous PDT using a focused laser diode light source.

25 Figure 1B shows PDT using a laser diode light source, where the light travels along the vessel wall to plaque with light scattering in plaque.

Figure 2 shows PDT using an optical fiber delivery of light from a laser diode light source (not shown).

Figure 3 shows PDT using an LED light source.

30 Figure 4 shows PDT using an optical diffuser attached to an optical fiber with delivery of light from a laser diode light source (not shown).

DETAILED DESCRIPTION OF THE INVENTION

This invention provides methods and compositions for treating a target tissue or destroying or impairing a target cell or composition in a mammalian subject by the specific and selective binding to the target tissue, cell or composition of a photosensitizer agent. This method comprises irradiating at least a portion of the subject with light at a wavelength absorbed by said photosensitizing agent that under conditions of activation during photodynamic therapy using a relatively low fluence rate, but an overall high total fluence dose results in minimal collateral tissue damage.

Terms as used herein are based upon their art recognized meaning and from the present disclosure should be clearly understood by the ordinary skilled artisan. For sake of clarity, terms may also have particular meaning as would be clear from their use in context. For example, transcutaneous more specifically herein refers to the passage of light through unbroken tissue. Where the tissue layer is skin or dermis, transcutaneous includes transdermal and the light source is external to the outer skin layer. However, where transillumination refers herein to the passage of light through a tissue layer, such as the outer layer of a blood vessel, the light source is external to the blood vessel, but internal or implanted into the subject or patient.

Specifically, the present invention is based on the precise targeting of photosensitive agents or drugs and compounds to specific target antigens of a subject or patient and to the method of activation of targeted photosensitizer agents by subsequently administering to the subject light of a relatively low fluence rate over a prolonged period of time from a light source that is external to the target tissue in order to achieve maximal cytotoxicity or reduction of plaque or abnormal intima with minimal side effects or collateral tissue damage.

Further, as used herein "target cells" or "target tissues" are those cells or tissues, respectively that are intended to be impaired or destroyed by this treatment method. Target cells or target tissues take up the photosensitizing agent; then when sufficient radiation is applied, these cells or tissues are impaired or destroyed. Target cells are those cells in target tissues, which include, but are not limited to: vascular lesions, thick or thin neointimas, arterial plaques, neoplasms, vascular smooth muscle cells and the abnormal extracellular matrix of the site to be treated.. "Non-target cells" are all the cells of an intact animal which are not intended to be impaired or destroyed by the treatment method. These non-target cells include but are not limited to healthy

blood cells, and other normal tissue, not otherwise identified to be targeted.

"Destroy" is used to mean kill the desired target cell. "Impair" means to change the target cell in such a way as to interfere with its function. For example, North *et al.* observed that after exposure to light of benzoporphyrin derivatives ("BPD")-treated, virus-infected T cells, holes developed in the T cell membrane, which increased in size until the membrane completely decomposed (Blood Cells 18:129-40, 1992). Target cells are understood to be impaired or destroyed even if the target cells are ultimately disposed of by macrophages.

"Photosensitizing agent" is a chemical compound which homes to one or more types of selected target cells and, when contacted by radiation, absorbs the light, which results in impairment or destruction of the target cells. Virtually any chemical compound that homes to a selected target and absorbs light may be used in this invention. Preferably, the chemical compound is nontoxic to the animal to which it is administered or is capable of being formulated in a nontoxic composition. Preferably, the chemical compound in its photodegraded form is also nontoxic. A comprehensive listing of photosensitive chemicals may be found in Kreimer-Birnbaum, *Sem. Hematol.* 26:157-73, 1989. Photosensitive compounds include, but are not limited to, chlorins, bacteriochlorins, phthalocyanines, porphyrins, purpurins, merocyanines, psoralens, benzoporphyrin derivatives (BPD) and porfimer sodium and pro-drugs such as .delta.-aminolevulinic acid, which can produce drugs such as protoporphyrin. Other compounds include indocyanine green (ICG); methylene blue; toluidine blue; texaphyrins; and any other agent that absorbs light in a range of 500 nm -1100 nm.

"Radiation" as used herein includes all wave lengths. Preferably, the radiation wave length is selected to match the wave length(s) which excites the photosensitive compound. Even more preferably, the radiation wave length matches the excitation wave length of the photosensitive compound and has low absorption by the non-target cells and the rest of the intact animal, including blood proteins. For example, the preferred wave length for ICG is the range of 750-850 nm.

The radiation is further defined in this invention by its intensity, duration, and timing with respect to dosing with the photosensitive agent. The intensity or fluence rate must be sufficient for the radiation to penetrate skin and reach the target cells, target tissues or target compositions. The duration or total fluence dose must be sufficient to photoactivate enough photosensitive agent to act on the target cells. Both

intensity and duration must be limited to avoid overtreating the animal. Timing with respect to dosing with the photosensitive agent is important, because 1) the administered photosensitive agent requires some time to home in on target cells and 2) the blood level of many photosensitive agents decreases rapidly with time.

5 This invention provides a method of treating an animal, which includes, but is not limited to, humans and other mammals. The term "mammals" or "mammalian subject" also includes farm animals, such as cows, hogs and sheep, as well as pet or sport animals such as horses, dogs and cats.

10 By "intact animal" is meant that the whole, undivided animal is available to be exposed to radiation. No part of the animal is removed for separate radiation, in contrast with photophoresis, in which the animal's blood is circulated outside its body for exposure to radiation. The entire animal need not be exposed to radiation. Only a portion of the intact animal subject may or need be exposed to radiation.

15 "Transcutaneously" is used herein as meaning through the skin of an animal subject.

Briefly, the photosensitizing agent is generally administered to the animal before the animal is subjected to radiation.

20 Preferred photosensitizing agents include, but are not limited to, chlorins, bacteriochlorins, phthalocyanines, porphyrins, purpurins, merocyanines, psoralens and pro-drugs such as delta-aminolevulinic acid, which can produce drugs such as protoporphyrin. More preferred are: methylene blue; toluidine blue; texaphyrins; and any other agent that absorbs light in a range of 500 nm -1100 nm. Most preferred is indocyanine green (ICG) (for example, see: WO 92/00106 (Raven *et al.*);

WO97/31582 (Abels *et al.*) and Devoisselle *et al.*, *SPIE* 2627:100-108, 1995).

25 The photosensitizing agent is administered locally or systemically. The photosensitizing agent is administered orally or by injection which may be intravenous, subcutaneous, intramuscular or intraperitoneal. The photosensitizing agent also can be administered enterally or topically via patches or implants.

30 The photosensitizing agent also can be conjugated to specific ligands reactive with a target, such as receptor-specific ligands or immunoglobulins or immunospecific portions of immunoglobulins, permitting them to be more concentrated in a desired target cell or microorganism. The photosensitizing agent may be further conjugated to a ligand-receptor binding pair, which includes, but is not

limited to: biotin-streptavidin; and antigen-antibody. This conjugation may permit lowering of the required dose level since the material is more selectively target and less is wasted in distribution into other tissues whose destruction must be avoided.

The photosensitizing agent can be administered in a dry formulation, such as pills, capsules, suppositories or patches. The photosensitizing agent also may be administered in a liquid formulation, either alone with water, or with pharmaceutically acceptable excipients; such as are disclosed in Remington's Pharmaceutical Sciences. The liquid formulation also can be a suspension or an emulsion. In particular, liposomal or lipophilic formulations are most desirable. If suspensions or emulsions are utilized, suitable excipients include water, saline, dextrose, glycerol, and the like. These compositions may contain minor amounts of nontoxic auxiliary substances such as wetting or emulsifying agents, antioxidants, pH buffering agents, and the like.

The dose of photosensitizing agent will vary with the target cell(s) sought, the optimal blood level (see Example 1), the animal's weight and the timing of the radiation. Depending on the photosensitizing agent used, an equivalent optimal therapeutic level will have to be established. Preferably, the dose is calculated to obtain a blood level between about 0.001 and 100  $\mu\text{g/ml}$ . Preferably, the dose will obtain a blood level between about 0.01 and 10  $\mu\text{g/ml}$ .

This method comprises irradiating at least a portion of the subject with light at a wavelength or waveband absorbed by said photosensitizing agent that under conditions of activation during photodynamic therapy using a relatively low fluence rate, but also at an overall high total fluence dose resulting in minimal collateral tissue damage. It is contemplated that the optimal total fluence will be determined clinically using a light dose escalation trial. It is further contemplated that the total fluence will preferably be in the range of 30 Joules to 25,000 Joules, and more preferably be in the range from 100 Joules to 20,000 Joules, and most preferably be in the range from 500 Joules to 10,000 Joules. The methods comprise irradiating at least a portion of the subject with light at a wavelength or waveband absorbed by said photosensitizing agent that under conditions of activation during photodynamic therapy using a relatively low fluence rate, but an overall high total fluence dose resulting in minimal collateral normal tissue damage. What is meant by "relatively low fluence rate" is a fluence rate that is lower than that typically used and one that generally does not



result in significant damage to collateral or non-target tissues. Specifically, the intensity of radiation used to treat the target cell or target tissue is preferably between about 5 and 100 mW/cm.<sup>2</sup>. More preferably, the intensity of radiation is between about 10 and 75 mW/cm.<sup>2</sup>. Most preferably, the intensity of radiation is between about 15 and 50 mW/cm.<sup>2</sup>.

The duration of radiation exposure is preferably between about 30 minutes and 72 hours. More preferably, the duration of radiation exposure is between about 60 minutes and 48 hours. Most preferably, the duration of radiation exposure is between about 2 hours and 24 hours.

The total number of joules delivered to the treatment site is contemplated to lie between 30 J-25,000 J, more preferably between 100 J-20,000 J, and most preferably between 500 J-10,000 J.

Of course, clinical testing will be required to determine the optimal fluence rate and total fluence delivered to the treatment site.

While not wishing to be limited by a theory, the inventor proposes that a photosensitizer agent can be substantially and selectively photoactivated in the target cells and target tissues within a therapeutically reasonable period of time and without excess toxicity or collateral damage to non-target tissues. Thus, there appears to be a therapeutic window bounded by the photosensitizer agent dosage and radiation dosage. The formation of photodegradation products of a photosensitizer agent was used as an indicator of photoactivation. Photoactivation of a photosensitizer agent has been postulated to cause the formation of singlet oxygen, which has a cytotoxic effect.

Additionally, the present invention is drawn to a method for transcutaneous ultrasonic therapy of tumors in a mammalian subject or patient by first administering to the subject a therapeutically effective amount of a first conjugate comprising a first member of a ligand-receptor binding pair conjugated to an antibody or antibody fragment, wherein said antibody or antibody fragment selectively binds to a target antigen of thick or thin neointimas, arterial plaques, , vascular smooth muscle cells and/or the abnormal extracellular matrix of the site to be treated.; and simultaneously or subsequently administering to the subject a therapeutically effective amount of a second conjugate comprising a second member of the ligand-receptor binding pair conjugated to an ultrasonic sensitizing agent or ultrasonic sensitizing agent delivery

system or prodrug, wherein the first member binds to the second member of the ligand-receptor binding pair. These steps are followed by irradiating at least a portion of the subject with energy at a wavelength absorbed by said ultrasonic sensitizing agent or if ultrasonic sensitizing agent delivery system, by the product thereof, wherein said energy is provided by an energy source that is external to the subject; and wherein said ultrasound is at a relatively low intensity rate that results in the activation of said ultrasonic sensitizing agent or prodrug product.

While a preferred embodiment of the present invention is drawn to the use of light energy in a light or photodynamic therapy of tumors using light or photosensitizer agents, other forms of energy are within the scope of this invention and understandable by one of ordinary skill in the art. Such forms of energy include, but are not limited to: thermal; sonic; ultrasonic; chemical; photo or light; microwave; ionizing, such as: x-ray, and gamma ray; and electrical. For example, sonodynamically induced or activated agents include, but are not limited to: gallium-porphyrin complex (see: Yumita *et al.*, *Cancer Letters*, 112: 79-86, 1997); other porphyrin complexes, such as protoporphyrin and hematoporphyrin (see: Umemura *et al.*, *Ultrasonics Sonochemistry* 3: S187-S191, 1996); other cancer drugs, such as daunorubicin and adriamycin, used in the presence of ultrasound therapy (see: Yumita *et al.*, *Japan J. Hyperthermic Oncology*, 3(2): 175-182, 1987).

This invention further contemplates the use of an energy source, preferably a light source, that is external to the target tissue. The target tissues may include and may relate to the atherosclerotic lesions, restenotic lesions and the lesion antigens, per se. These target lesion antigens would be readily understood by one of ordinary skill in the art therefore to include but to not be limited to: tumor surface antigen; tumor endothelial antigen; non-tumor endothelial antigen; tumor vessel wall antigen; neointimal antigens; arterial plaque antigens; and vascular smooth muscle cell antigens.

The ordinary skilled artisan would be familiar with various ligand-receptor binding pairs, including those known and those currently yet to be discovered. Those known, include, but are not limited to the group consisting of: biotin-streptavidin; and antigen-antibody. This invention contemplates a preferred embodiment that includes the use of biotin-streptavidin as the ligand-receptor binding pair. However, the ordinary skilled artisan would readily understand from the present disclosure that

any ligand-receptor binding pair may be useful provided the ligand-receptor binding pair demonstrate a specificity for the binding by the ligand to the receptor and further provided that the ligand-receptor binding pair permit the creation of a first conjugate comprising a first member of the ligand-receptor binding pair conjugated to an antibody or antibody fragment, wherein said antibody or antibody fragment selectively binds to a target antigen of thick or thin neointimas, arterial plaques, , vascular smooth muscle cells and/or the abnormal extracellular matrix of the site to be treated; and further permit the creation of a second conjugate comprising a second member of the ligand-receptor binding pair conjugated to an energy sensitizing or photosensitizing agent or energy sensitizing or photosensitizing agent delivery system or prodrug, and further wherein the first member binds to the second member of the ligand-receptor binding pair.

A preferred embodiment of the present invention is drawn to a method where the photosensitizing agent delivery system includes a liposome delivery system consisting essentially of the photosensitizing agent, however the ordinary skilled artisan would readily understand from the present disclosure that other delivery systems may be used. A still further and preferred embodiment of the present invention contemplates the disclosed method where the photosensitizing agent delivery system utilizes both a liposome delivery system and a photosensitizing agent, where each is separately conjugated to a second member of the ligand-receptor binding pair, and where the first member binds to the second member of the ligand-receptor binding pair, and more preferably where the ligand-receptor binding pair is biotin-streptavidin. This embodiment further contemplates that the photosensitizing agent as well as the photosensitizing agent delivery system may both be specifically targeted through the selective binding to a target tissue antigen by the antibody or antibody fragment of the first member binding pair. Such dual targeting is envisioned to enhance the specificity of uptake and to increase the quantity of uptake.

Having now generally described the invention, the same will be more readily understood through reference to the following examples which are provided by way of illustration, and are not intended to be limiting of the present invention, unless specified.

EXAMPLE 1Transcutaneous Photodynamic Therapy of Vascular Lesions

5 Occlusive peripheral vascular disease, restenosis and other vascular lesions may be effectively treated by transcutaneous photodynamic therapy. Restenosis, the formation of a thick neointima due to the accumulation of proliferative smooth muscle cells and extracellular matrix at an injured site, is a frequent complication of surgical and percutaneous interventions for occlusive peripheral vascular disease. Restenosis occurs as a result of the natural reparative process and is proportional to the degree of injury inflicted upon the arterial wall. The current therapies include surgery, administration of anticoagulants such as Heparin®, vasoconstrictors such as Angiotensin II®, antiproliferative agents such as Angiopeptin®, Maphthopyran and Mycophenolate mofetil.

10 Since Heparin® has a high-binding capacity to basic fibroblast growth factor and is also a potent antiproliferative agent and Angiotensin II® is a polypeptide that induces vasoconstriction by binding to receptors on vascular smooth muscle cells; Heparin® or Angiotensin II® may be used to localize a photosensitizer agent to the vascular region in a mammalian subject to be treated. Alternatively, the photosensitizer may be conjugated to LDL, VLDL, or a similar agent that specifically binds to arterial plaques and/or vascular lesions.

20 Therefore, a photosensitizer agent is conjugated to a Heparin®, Angiotensin II®, LDL, VLDL, , or a similar agent which binds selectively to the thick neointimas, arterial plaques, neoplasms, vascular smooth muscle cells and/or the extracellular matrix of the site to be treated. Excess photosensitizer conjugates are eliminated from the body. One or more light sources are strategically placed or implanted near the tissue to be treated. Following a sufficient amount of time to permit clearing of the conjugates from the non-target tissues, the light sources are activated, irradiating the target tissue with a relatively low fluence rate, but high total fluence dose of light in the wavelength from about 750 nm to about 850 nm. The light may be applied internally or externally, with the external light source the preferred mode.

30 The specific dose of photosensitizer conjugate is that which results in a concentration of active ICG sufficient to obtain a blood level between about 0.001 and 100 µg/ml. and more preferably, a dose of between about 0.01 and 10 µg/ml. However, it is well within the skill of the ordinary skilled artisan to determine the

specific therapeutically effective dose using standard clinical practices and procedures.

Similarly, the specific fluence rate and total fluence dose may be routinely determined from the disclosure herein.

5           Additionally, the conjugate above could be further conjugated to an imaging agent such as technetium. Thus, the method could further comprise the steps of performing a nuclear medicine scan and imaging the vascular sites to be treated.

10           B.     A targeted antibody-photosensitizer conjugate (APC) is constructed which binds selectively to antigens mainly present on neointimas, arterial plaques and/or vascular smooth muscle cells. This ligand-receptor binding pair or APC is infused intravenously and is taken up in the neointimas, arterial plaques, neoplasms, vascular smooth muscle cells and/or the extracellular matrix. When unbound, APC is eliminated from the body. Internal or external light sources may be used to activate  
15           the targeted drug.

          Any number of antigens may be selected, provided that the antigen is specific for the neointimas, arterial plaques, neoplasms, vascular smooth muscle cells and/or the abnormal extracellular matrix. Such antigens would be known to those skilled in the art. The selection of a specific photosensitizer agent may be made, provided the  
20           photosensitizer agent is activated by a light wavelength of from 500 nm to 1100 nm, and more preferably a wavelength of 650 nm, and most preferably by a wavelength of 700 nm or greater. Such photosensitizer agents as provided in this disclosure are contemplated for use herein.

25           C.     The PDT light source is an externally positioned light source directed at the site to be treated. The light source may be a laser diode, light emitting diode or other electroluminescent device. The light source is angled and the light beam is focused to as to direct the light through the skin or membrane of the mammalian subject being treated in a direction lengthwise and parallel to the vessel wall. See  
          Figures 1A and 1B.

30           Alternatively, the light source could comprise a laser diode coupled to an optical fiber which is then aimed at the vessel so as to direct the light along the length of the vessel. See Figure 2. The light source could also comprise a strip of light emitting diodes (LEDs) which are then arrayed on the skin or the membrane

overlying the site to be treated in the mammalian subject. See Figure 3. The light source could also comprise an optical fiber diffuser which is placed over the skin or the membrane overlying the site to be treated in the mammalian subject. See Figure 4.

5

D. As is apparent to one of ordinary skill in the art, the methods and compositions described above have various applications. For example, a group of small vessels in a mammalian subject may be treated by utilizing a patch composed of LEDs or a mat of woven optical fibers wherein the light source patch or mat is placed over the skin or the tissue overlying the site to be treated. Furthermore, the patch or mat could also contain pharmaceutical compositions or the photosensitizing agent which is then delivered by liposomal, transdermal or iontophoretic techniques. Additionally, vein grafts and artificial grafts could similarly be treated by the methods and compositions described above.

10

15

This invention has been described by a direct description and by examples. As noted above, the examples are meant to be only examples and not to limit the invention in any meaningful way. Additionally, one having ordinary skill in the art to which this invention pertains in reviewing the specification and claims which follow would appreciate that there are equivalents to those claimed aspects of the invention. The inventors intend to encompass those equivalents within the reasonable scope of the claimed invention.

20

CLAIMS

1. A method for destroying or impairing target cells that comprise a lesion in the vascular system in a mammalian subject comprising:

5 administering to the subject a therapeutically effective amount of a photosensitizing agent, wherein said photosensitizing agent selectively binds to target cells of the lesion;

irradiating at least a portion of the subject with light at a wavelength absorbed by said photosensitizing agent, wherein said light is provided by a light source that is  
10 external to the intact body of the subject; and wherein said irradiation is at a relatively low fluence rate that results in the activation of said photosensitizing agent or said prodrug product

wherein said PDT drug is cleared from the skin and subcutaneous tissues of the subject prior to said irradiation.

15 2. A method for destroying or impairing target cells that comprise a lesion in the arterial vascular system in a mammalian subject comprising:

administering to the subject a therapeutically effective amount of a first conjugate comprising a first member of a ligand-receptor binding pair conjugated to  
20 an antibody or antibody fragment, wherein said antibody or antibody fragment selectively binds to a target cell or target tissue antigen;

administering to the subject a therapeutically effective amount of a second conjugate comprising a second member of the ligand-receptor binding pair conjugated to a photosensitizing agent or photosensitizing agent delivery system or prodrug,  
25 wherein the first member binds to the second member of the ligand-receptor binding pair;

irradiating at least a portion of the subject with light at a wavelength absorbed by said photosensitizing agent, wherein said light is provided by a light source that is external to the subject; and wherein said irradiation is at a relatively low fluence rate  
30 that results in the activation of said photosensitizing agent or prodrug product.

3. The method of claim 1 or 2, wherein said light source is selected from the group consisting of one or a plurality of: laser diodes, fiber lasers, LEDs, non-laser light source, cold cathode fluorescent tube, incandescent lights, halogen lights,

polymeric luminescent devices, other types of fluorescent lights, discharge lamps, and other electroluminescent devices.

- 5 4. The method of claim 1 or 2, wherein said light is directed through the skin in a direction parallel and lengthwise to the wall of a vascular vessel having the lesion.
- 10 5. The method of claim 3, wherein said laser diode is coupled to an optical fiber, and wherein said optical fiber directs said light lengthwise to the vessel wall having the lesion.
- 15 6. The method of claim 3, wherein said light emitting diode is a light emitting diode strip, and wherein said light emitting diode strip is placed over the skin overlying the lesion.
7. The method of claim 5, wherein said optical fiber diffuses said light when placed over the vessel wall having the lesion.
- 20 8. The method of claim 5, wherein said light source is a mat comprising a plurality of said optical fiber.
- 25 9. The method of claim 1 or 2, wherein said photosensitizing agent is selected from the group consisting of: indocyanine green; methylene blue; lutetium texaphyrin; toluidine blue; aminolevulinic acid (ALA) and any other agent that absorbs light in a range of 600 nm -1100 nm; and wherein said agent may be delivered as a delivery system or as a prodrug, the product thereof resulting in the photosensitize agent.
- 30 10. The method of claim 1 or 2, wherein said wavelength is from about 600 nm to about 1100 nm.
11. The method of claim 10, wherein said wavelength is greater than about 700 nm.



12. The method of claim 11, wherein said light results in a single photon absorption mode by the photosensitizing agent.

5 13. The method of claim 9, wherein a complex, comprising said photosensitizing agent conjugated to LDL or VLDL, localizes in the lesion.

14. The method of claim 13, wherein said complex is administered intravenously.

10 15. The method of claim 2, wherein said target tissue antigen is selected from the group consisting of: tumor surface antigen; tumor endothelial antigen; non-tumor endothelial antigen; and tumor vessel wall antigen.

15 16. The method of claim 2, wherein said ligand-receptor binding pair is selected from the group consisting of: biotin-streptavidin; chemokine-chemokine receptor; growth factor-growth factor receptor; and antigen-antibody.

20 17. The method of claim 1 or 2, wherein said photosensitizing agent delivery system comprises a liposome delivery system consisting essentially of the photosensitizing agent.

25 18. The method of claim 1 or 2, wherein said light source is pulse modulated to maximize depth of tissue penetration and minimize heat generation and power consumption.

19. The method of claim 1 or 2, wherein the total fluence of the light used for irradiating is between about 30 Joules/cm<sup>2</sup> and about 25,000 Joules/cm<sup>2</sup>.

30 20. The method of claim 1 or 2, wherein the total fluence of the light used for irradiating is between about 100 Joules/cm<sup>2</sup> and about 20,000 Joules/cm<sup>2</sup>.

21. The method of claim 1 or 2, wherein the total fluence of the light used for irradiating is between about 500 Joules/cm<sup>2</sup> and about 10,000 Joules/cm<sup>2</sup>.

5 22. An apparatus for transcutaneous photodynamic therapy of a lesion in the vascular system in a mammalian subject comprising a light source that is external to the subject and is selected from the group consisting of one or a plurality of: laser diodes; light emitting diodes; electroluminescent light sources; incandescent light sources; cold cathode fluorescent light sources; organic polymer light sources; or inorganic light sources.

10 23. The apparatus of claim 22, wherein said light source is at least one laser diode coupled to an optical fiber which directs said light lengthwise to the vessel wall having the lesion.

15 24. The apparatus of claim 23, wherein said diode is a light emitting diode strip, and wherein said light emitting diode strip may be placed over the skin overlying the lesion.

---

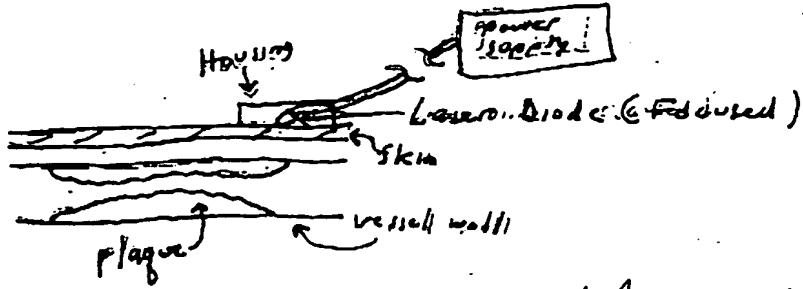

Figure 1A

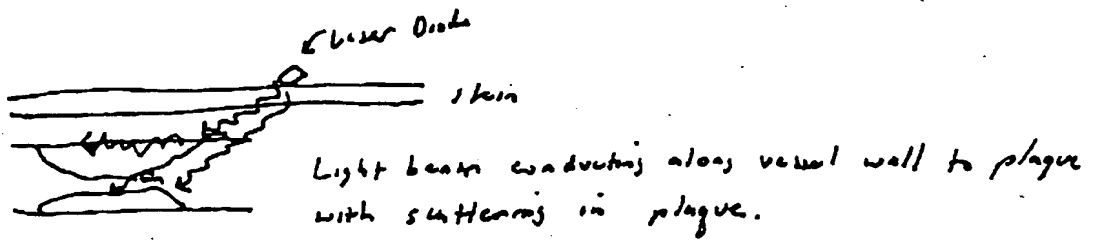

Figure 1B

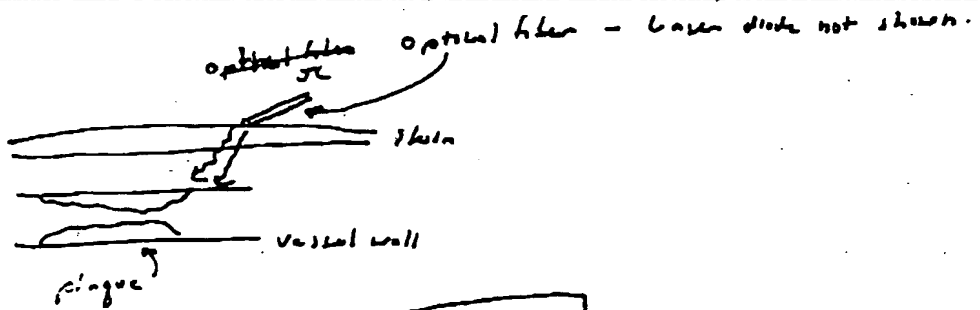

Figure 2

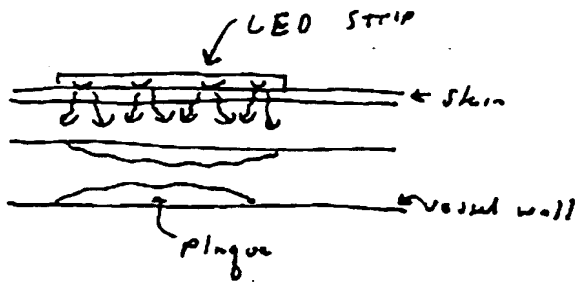

Figure 3

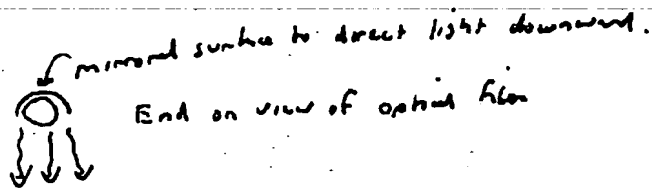
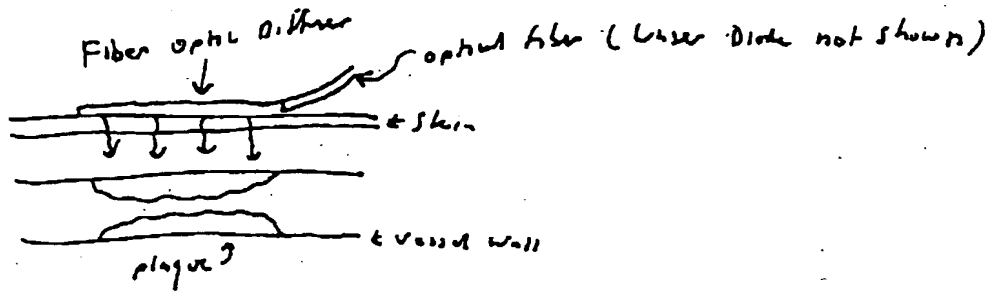

Figure 4

(12) INTERNATIONAL APPLICATION PUBLISHED UNDER THE PATENT COOPERATION TREATY (PCT)

CORRECTED VERSION

(19) World Intellectual Property Organization  
International Bureau



(43) International Publication Date  
20 July 2000 (20.07.2000)

PCT

(10) International Publication Number  
WO 00/41726 A3

(51) International Patent Classification<sup>7</sup>: A61K 41/00

(21) International Application Number: PCT/US00/00852

(22) International Filing Date: 14 January 2000 (14.01.2000)

(25) Filing Language: English

(26) Publication Language: English

(30) Priority Data:  
60/116,235 15 January 1999 (15.01.1999) US

(71) Applicant (for all designated States except US): LIGHT SCIENCES CORPORATION [US/US]; No.E-5, 1065 12th Avenue N.W., Issaquah, WA 98027 (US).

(72) Inventor; and  
(75) Inventor/Applicant (for US only): CHEN, James [US/US]; 2011 - 87th Place N.E., Bellevue, WA 98004 (US).

(74) Agents: MAYS, Thomas, D. et al.; Morrison & Foerster LLP, 2000 Pennsylvania Avenue N.W., Washington, DC 20006-1888 (US).

(81) Designated States (national): AL, AM, AT, AU, AZ, BA, BB, BG, BR, BY, CA, CH, CN, CR, CU, CZ, DE, DK, DM,

EE, ES, FI, GB, GD, GE, GH, GM, HR, HU, ID, IL, IN, IS, JP, KE, KG, KP, KR, KZ, LC, LK, LR, LS, LT, LU, LV, MA, MD, MG, MK, MN, MW, MX, NO, NZ, PL, PT, RO, RU, SD, SE, SG, SI, SK, SL, TJ, TM, TR, TT, UA, UG, US, UZ, VN, YU, ZA, ZW.

(84) Designated States (regional): ARIPO patent (GH, GM, KE, LS, MW, SD, SL, SZ, TZ, UG, ZW), Eurasian patent (AM, AZ, BY, KG, KZ, MD, RU, TJ, TM), European patent (AT, BE, CH, CY, DE, DK, ES, FI, FR, GB, GR, IE, IT, LU, MC, NL, PT, SE), OAPI patent (BF, BJ, CF, CG, CI, CM, GA, GN, GW, ML, MR, NE, SN, TD, TG).

Published:  
— With international search report.

(88) Date of publication of the international search report:  
2 November 2000

(48) Date of publication of this corrected version:  
12 July 2001

(15) Information about Correction:  
see PCT Gazette No. 28/2001 of 12 July 2001, Section II

For two-letter codes and other abbreviations, refer to the "Guidance Notes on Codes and Abbreviations" appearing at the beginning of each regular issue of the PCT Gazette.

WO 00/41726 A3

(54) Title: NONINVASIVE VASCULAR THERAPY

(57) Abstract: The present invention is drawn to methods and compounds for transcutaneous photodynamic therapy ("PDT") of a target tissue or compositions in a mammalian subject, which includes administering to the subject a therapeutically effective amount of a photosensitizing agent or a photosensitizing agent delivery system or a prodrug, where the photosensitizing agent or photosensitizing agent delivery system or prodrug selectively binds to the target tissue; and irradiating at least a portion of the subject with light at a wavelength absorbed by the photosensitizing agent or if prodrug, by a prodrug product thereof, where the light is provided by a light source, and where the irradiation is at low fluence rate that results in the activation of the photosensitizing agent or prodrug product. These methods of transcutaneous PDT are useful in the treatment of specifically selected target tissues, such as: vascular endothelial tissue; abnormal vascular wall of tumors; tumors of the head and neck; tumors of the gastrointestinal tract; tumors of the liver; tumors of the esophopharyngeal; tumors of the lung; lymphoid tissue; lesions in the vascular system; bone marrow and tissue related to autoimmune disease.

## NONINVASIVE VASCULAR THERAPY

### TECHNICAL FIELD OF THE INVENTION

This invention relates generally to the field of medicine and pharmacotherapeutics with photosensitizing agents or other energy activated agents. Specifically, this invention relates to methods, compounds, compositions and kits useful for site specific delivery to a lesion target site of a therapeutically effective amount of a photosensitizing agent that is activated by a relatively low fluence rate of light over a prolonged period of time. This invention further relates to the use of either an external or internal light source effective in providing transcutaneous photodynamic therapy as a treatment modality for atherosclerotic lesions and restenotic lesions in vivo.

### BACKGROUND OF THE INVENTION

One form of energy activated therapy is photodynamic therapy (PDT). PDT has been applied to the vascular system to treat atherosclerotic lesions and restenotic lesions in vivo.

PDT is performed by first administering a photosensitive compound systemically or topically, followed by illumination of the treatment site at a wavelength or waveband which closely matches the absorption spectra of the photosensitizer. In doing so, singlet oxygen and other reactive species are generated leading to a number of biological effects resulting in cytotoxicity. The depth and volume of the cytotoxic effect in tissue depends on the complex interactions of light penetration in tissue, the photosensitizer concentration and cellular location, and availability of molecular oxygen.

Vascular lesions are typically treated by light delivered from within the vessel by a fiberoptic probe as described by Mackie *et al* (Lasers in Surgery and Medicine 11:535-544 (Wiley-Liss, Inc. 1991)). Since light is delivered from within the lumen of the vessel, the vessel by necessity must be punctured in order to introduce the optical fiber. Puncture of an arterial vessel is associated with various medical risks including downstream embolization from intravascular dislodgement of plaque or other debris; bleeding of the puncture site at the skin or vessel; heparinization may cause bleeding or other side effects; intimal flap from passage of the optical fiber causing

downstream infarction; repeat procedures pose increased total risk; infection from the optical fiber; thrombosis of the treated vessel; aneurysm formation; and perforation of the vessel wall. Furthermore, invasive PDT has other disadvantages such as inability to treat small vessel disease where the vessel(s) cannot be treated because the vessel diameter is too small and where it is unsafe to subject the patient to an invasive procedure which may increase risk of complications especially where infection and bleeding disorders pre-exist.

A large number of PDT light sources and methods of use have been described. However, reports describing the sources and effects of transcutaneous light delivery for PDT purposes are more limited. It has generally been accepted that the ability of a light source external to the body to cause clinically useful cytotoxicity is limited in depth to a range of 1-2 cm or less depending on the photosensitizer. Treatment of superficial tumors in this manner may be associated with inadvertent skin damage due to accumulation of the photosensitizer in the skin which is a property of all systemically administered sensitizers in clinical use. For example, clinically useful porphyrins such as Photophrin® (QLT, Ltd. brand of sodium porfimer) are associated with photosensitivity lasting up to 6 weeks. Purlytin®, which is a purpurin and Foscan® which is a chlorin sensitize the skin for several weeks. Indeed, efforts have been made to develop photoprotectants to reduce skin photosensitivity (see: Dillon *et al.*, *Photochemistry and Photobiology*, 48(2): 235-238, 1988; and Sigdestad *et al.*, *British J. of Cancer*, 74:S89-S92, 1996). In fact, PDT protocols involving systemic administration of photosensitizer require that the patient avoid sunlight and bright indoor light to reduce the chance of skin phototoxic reactions.

Recently, it has been claimed that with a sufficiently intense laser external light source causing two-photon absorption by a photosensitizer, it is theoretically possible to cause a very limited volume of cytotoxicity transcutaneously at greater depths. However, no clinical studies exist to support this contention. One would expect that the passage of an intense beam of light through the skin would lead to the same risk of injury to non-target tissues, such as skin and subcutaneous tissue, if used in conjunction with a systemically administered photosensitizer.

For example, one PDT modality discloses the use of an intense laser source to activate drug within a precisely defined boundary (see: Fisher *et al.*, "Method for improved selectivity in photo-activation of molecular agents", U.S. Pat. No.

5,829,448). The two-photon methodology requires a high power laser for drug activation with a highly collimated beam that requires a high degree of spatial control. For a large tumor this treatment is not practical since the beam would have to be swept across the skin surface in some sort of set, repeatable pattern over time. Patient or organ movement would be a problem, because the beam could become misaligned. Non-target tissue or skin and subcutaneous tissue photosensitivity is not addressed in the literature available. Any sensitizer in the path of the beam would be activated and cause unwanted collateral tissue damage. The present disclosure is a one-photon method and therefore teaches away from the two-photon method. Further, the present invention teaches and enables the prolonged exposure at a lower fluence rate, which promotes the protection of non-target tissue or skin and subcutaneous normal tissue and reduces collateral tissue damage.

Other modalities have employed the use of low total fluence of PDT delivered over a short time period to avoid skin photoactivation and the use of drug administration timing methods to enable destruction of small tumors in animals (see: U.S. Patent 5,705,518 (Richter *et al.*). However, the present disclosure teaches away from this method in order to enable large total fluence PDT, but at a lower fluence rate, which enables the treatment of larger tumor volumes. Richter *et al.* further fails to teach or disclose the suggestion of a targeting scheme as presently disclosed.

In the event that the target lesion lies below an intact cutaneous layer, the main drawbacks of all transcutaneous illumination methods, whether they be external laser or external nonlaser light sources, are: 1) the risk of damage to non-target tissues, such as the more superficial cutaneous and subcutaneous tissues overlying the target lesion, 2) limitation of treatment volume, and 3) limitation of treatment depth. Damage to normal tissue between the light source and the target occurs due to the uptake of photosensitizer by the skin and other tissues overlying the lesion with resultant unwanted photoactivation in these tissues. The consequences of inadvertent skin damage caused by transcutaneous light delivery to a subcutaneous lesion may include severe pain, serious infection, and fistula formation. The limited volume of a target lesion that can be clinically treated and the limitations of the light penetration below the skin surface in turn have limited clinical transcutaneous PDT to superficial, thin lesions.



Clearly, there would be significant advantage to a completely noninvasive form of PDT directed to subcutaneous vascular lesions which avoids the inadvertent activation of photosensitizer in skin and intervening tissues and also avoids damaging the vessel walls. To date, this feasibility has not been clinically demonstrated nor realized. Only in animal studies utilizing mice or other rodents with very thin cutaneous tissue layers, have very small superficial subcutaneous malignant tumors been treated. These *in vivo* studies do not enable or teach the safe application of transcutaneous light sources to treat atherosclerotic lesions and restenotic lesions in humans, however.

This invention further discloses the selective binding of the photosensitizing agent to specific target tissue antigens, such as those found on the surface of or within vascular lesions. This targeting scheme decreases the amount of sensitizing drug required for effective therapy, which in turn reduces the total fluence, and the fluence rate needed for effective photoactivation. For example, the highly specific uptake of photosensitizer in atherosclerotic vessels using the avidin-biotin system would result in reduced or no skin uptake enabling safe transcutaneous photoactivation. While there are several reports in the scientific literature of utilizing the specificity of the binding between biotin and streptavidin to target tumor cells, there are no reports utilizing this ligand-receptor binding pair aimed at vascular lesions nor in conjunction with prolonged PDT light exposure (see, for example: Savitsky *et al.*, *SPIE*, 3191: 343-353, 1997; and Ruebner *et al.*, *SPIE*, 2625: 328-332, 1996). In a non-PDT modality, the biotin-streptavidin ligand-receptor binding pair have also been reported used as tumor targeting conjugates with radionuclides (see: U.S. Pat. No. 5,630,996 (Reno *et al.*) and with monoclonal antibodies (see: Casalini *et al.*; *J. Nuclear Med.*, 38(9): 1378-1381, 1997) and U.S. Pat. No. 5,482,698 (Griffiths)).

Other ligand-receptor binding pairs have been used in PDT for targeting tumor antigens, but also fail to teach their use in conjunction with blood vessel targeting or treatment of atherosclerotic and restenotic lesions (see: for example, Mew *et al.*, *J. of Immunol.*, 130(3): 1473-1477, 1983)

A light source far less intense than a high powered laser is used (see: W.G. Fisher, *et al.*, *Photochemistry and Photobiology*, 66(2):141-155, 1997). The present disclosure teaches the unexpected use of a low power non-coherent light source

utilized for longer than about 2 hours to increase photoactivation depth. This teaches away from the use of a high powered, brief exposure using collimated light as disclosed in W.G. Fisher, *et al.*, *Photochemistry and Photobiology*, 66(2):141-155, 1997..

5 Clearly, there is a need to improve the method of transcutaneous PDT to enable the safe and practical application of transcutaneous light to vascular lesions in large and small blood vessels without risking damage to non-target tissues, such as skin and normal subcutaneous tissue. The present disclosure teaches a method of photoactivation and photosensitizer construct which improves on the prior art by enabling PDT induced cytotoxicity on both macro- and microscopic scales without risk to the cutaneous layer. Also, the therapeutic index is enhanced due to a specific targeting scheme.

10 Citation of the above documents is not intended as an admission that any of the foregoing is pertinent prior art. All statements as to the date or representation as to the contents of these documents is based on the information available to the applicants and does not constitute any admission as to the correctness of the dates or contents of these documents. Further, all documents referred to throughout this application are incorporated in their entirety by reference herein.

#### 20 SUMMARY OF THE INVENTION

The present invention is based on the precise targeting of photosensitive agents or other energy activated agents, drugs and compounds to specific target cells or compositions of a subject or patient and to the method of activation of these targeted photosensitizer agents or other energy activated agents by subsequently administering to the subject light or ultrasonic energy at a relatively low intensity rate and over a prolonged period of time, utilizing a light or ultrasonic energy source that is either external or internal to the target tissues in order to achieve maximal cytotoxicity with minimal side effects.

30 One embodiment of the present invention is drawn to a method for transcutaneous photodynamic therapy ("PDT") of a vascular lesion in a mammalian subject comprising: administering to the subject a therapeutically effective amount of a photosensitizing agent or a photosensitizing agent delivery system or a prodrug, where the photosensitizing agent or photosensitizing agent delivery system or prodrug

selectively binds to the target tissue which is an atherosclerotic plaque. This step is followed by irradiating at least a portion of the subject with light at a wavelength or waveband absorbed by the photosensitizing agent or if a prodrug, by a prodrug product thereof, where the light is provided by a light source, and where the irradiation is at a relatively low fluence rate that results in the activation of the photosensitizing agent or prodrug product. In this embodiment of the present invention, the photosensitizing agent or photosensitizing agent delivery system or prodrug is cleared from non-target tissues of the subject prior to irradiation.

One other embodiment of the present invention is drawn to a method for transcutaneous PDT of a target composition in a mammalian subject comprising: administering to the subject a therapeutically effective amount of a photosensitizing agent or a photosensitizing agent delivery system or a prodrug, where the photosensitizing agent or photosensitizing agent delivery system or prodrug selectively binds to the target composition. This step is followed by irradiating at least a portion of the subject with light at a wavelength or waveband absorbed by the photosensitizing agent or if a prodrug, by a prodrug product thereof, where said light is provided by a light source, and where the irradiation is at a relatively low fluence rate that results in the activation of the photosensitizing agent or said prodrug product. This embodiment contemplates that the photosensitizing agent or the photosensitizing agent delivery system or prodrug is cleared from non-target tissues of the subject prior to said irradiation. This embodiment also contemplates that light is delivered from a relatively low power noncoherent or coherent light source that is positioned in proximity to the diseased vessel, beneath the skin surface and external to the diseased blood vessel. Another preferred embodiment of the present invention is drawn to a method of transcutaneous PDT of a target tissue in a mammalian subject as described above, where the light source is entirely external to the patient's intact skin layer.

Another embodiment of this invention is drawn to a method of transcutaneous PDT, where the photosensitizing agent is conjugated to a ligand. One preferred embodiment of this invention contemplates a method of transcutaneous PDT, where the ligand is an antibody specific to thick or thin neointimas, arterial plaques, vascular smooth muscle cells and/or the abnormal extracellular matrix of the site to be treated. Other preferred embodiments include methods of transcutaneous PDT, where the ligand is a peptide or polymer specific to thick or thin neointimas, arterial plaques, .

vascular smooth muscle cells and/or the abnormal extracellular matrix of the site to be treated..

A still further embodiment of the present invention is drawn to a method of transcutaneous PDT, where the photosensitizing agent is selected from the group consisting of: indocyanine green (ICG); methylene blue; toluidine blue;  
5 aminolevulinic acid (ALA); chlorin compounds; phthalocyanines; porphyrins; purpurins; texaphyrins; and any other agent that absorbs light in a range of 500 nm - 1100 nm. A preferred embodiment of this invention contemplates that the photosensitizing agent is indocyanine green (ICG).

10 One other embodiment of the present invention is drawn to a method of transcutaneous PDT, where the activation of the photosensitizing agent will likely occur within 30 minutes to 72 hours of irradiation, more preferably within 60 minutes to 48 hours of irradiation and most preferably within 3 hours to 24 hours of irradiation. Of course, clinical testing will be required to determine the optimal  
15 illumination time. In addition, it is contemplated that the total fluence delivered will preferably be between 30 Joules to 25,000 Joules, more preferably be between 100 Joules and 20,000 Joules, and most preferably be between 500 Joules to 10,000 Joules. Clinical testing will determine the optimal total fluence required to reduce the atheroma and undesirable tissue causing restenotic lesions.

20 A still further embodiment of this invention is drawn to a method for transcutaneous photodynamic therapy of target lesion in a mammalian subject comprising: administering to the subject a therapeutically effective amount of a first conjugate comprising a first member of a ligand-receptor binding pair conjugated to an antibody or antibody fragment, where the antibody or antibody fragment  
25 selectively binds to a target antigen found on thick or thin neointimas, arterial plaques, , vascular smooth muscle cells and/or the abnormal extracellular matrix of the site to be treated. This step is followed by administering to the subject a therapeutically effective amount of a second conjugate comprising a second member of the ligand-receptor binding pair conjugated to a photosensitizing agent or  
30 photosensitizing agent delivery system or prodrug, where the first member binds to the second member of the ligand-receptor binding pair. A subsequent step includes irradiating at least a portion of the subject with light at a wavelength or waveband absorbed by the photosensitizing agent or if prodrug, by the product thereof. This

embodiment further includes that the light is provided by a light source and that the irradiation is at a relatively low fluence rate that results in the activation of the photosensitizing agent or prodrug product.

5 Still further preferred embodiments of this invention are drawn to methods of transcutaneous PDT where the ligand-receptor binding pair is selected from the group consisting of: biotin-streptavidin; and antigen-antibody. A further preferred embodiment of the present invention is drawn to the presently disclosed methods where the antigens are vasculature antigens of the vascular lesion and the preferable ligand-receptor binding pair includes biotin-streptavidin. In this preferred  
10 embodiment, the activation of photosensitizer agents by a relatively low fluence rate light source over a prolonged period of time results in the destruction or reduction of the vascular lesion.

Another preferred embodiment contemplates a transcutaneous PDT method where the photosensitizing agent delivery system comprises a liposome delivery  
15 system consisting essentially of the photosensitizing agent.

Yet another embodiment of the present invention is drawn to a method for transcutaneous ultrasonic therapy of a target lesion in a mammalian subject comprising:

20 administering to the subject a therapeutically effective amount of an ultrasonic sensitizing agent or a ultrasonic sensitizing agent delivery system or a prodrug, where the ultrasonic sensitizing agent or ultrasonic sensitizing agent delivery system or prodrug selectively binds to the thick or thin neointimas, arterial plaques, s, vascular smooth muscle cells and/or the abnormal extracellular matrix of the site to be treated.. This step is followed by irradiating at least a portion of the subject with ultrasonic  
25 energy at a frequency that activates the ultrasonic sensitizing agent or if a prodrug, by a prodrug product thereof, where the ultrasonic energy is provided by an ultrasonic energy emitting source. This embodiment further provides that the ultrasonic therapy drug is cleared from non-target tissues of the subject prior to irradiation.

30 A preferred embodiment of this invention contemplates a method for transcutaneous ultrasonic therapy of a target tissue, where the target tissue is a lesion in the vascular system.

Other preferred embodiments of this invention contemplate that the ultrasonic energy emitting source is external to the patient's intact skin layer or is inserted

underneath the patient's intact skin layer, but is external to the blood vessel to be treated. An additional preferred embodiment of this invention provides that the ultrasonic sensitizing agent is conjugated to a ligand and more preferably, where the ligand is selected from the group consisting of: a target lesion specific antibody; a target lesion specific peptide and a target lesion specific polymer. Other preferred  
5  
embodiments of the present invention contemplate that the ultrasonic sensitizing agent is selected from the group consisting of: : indocyanine green (ICG); methylene blue; toluidine blue; aminolevulinic acid (ALA); chlorin compounds; phthalocyanines; porphyrins; purpurins; texaphyrins; and any other agent that absorbs light in a range  
10  
of 500 nm -1100 nm. A preferred embodiment of this invention contemplates that the photosensitizing agent is indocyanine green (ICG).

Other embodiments of the present invention are drawn to the presently disclosed methods of transcutaneous PDT, where the light source is positioned in  
15  
proximity to the target tissue of the subject and is selected from the group consisting of: an LED light source; an electroluminescent light source; an incandescent light source; a cold cathode fluorescent light source; organic polymer light source; and inorganic light source. A preferred embodiment includes the use of an LED light  
source.

Yet other embodiments of the presently disclosed methods are drawn to use of  
20  
light of a wavelength that is from about 500 nm to about 1100 nm, preferably greater than about 650 nm and more preferably greater than about 700 nm. A preferable embodiment of the present method is drawn to the use of light that results in a single photon absorption mode by the photosensitizing agent.

Additional embodiments of the present invention include compositions of  
25  
photosensitizer targeted delivery systems comprising: a photosensitizing agent; and a ligand that binds a receptor on the target tissue with specificity. Preferably, the photosensitizing agent of the targeted delivery system is conjugated to the ligand that binds a receptor on the target lesion with specificity. More preferably, the ligand  
30  
comprises an antibody that binds to a receptor. Most preferably, the receptor is an antigen on thick or thin neointimas, arterial plaques, , vascular smooth muscle cells and/or the abnormal extracellular matrix of the site to be treated..

A further preferred embodiment of this invention contemplates that the

photosensitizing agent is selected from the group consisting of: indocyanine green (ICG); methylene blue; toluidine blue; aminolevulinic acid (ALA); chlorin compounds; phthalocyanines; porphyrins; purpurins; texaphyrins; and any other agent that absorbs light in a range of 500 nm - 1100 nm.

5 Still another preferred embodiment of this invention contemplates that the ligand-receptor binding pair is selected from the group consisting of: biotin-streptavidin;; and antigen-antibody.

Yet another preferred embodiment contemplates that the photosensitizing agent comprises a prodrug.

10 Other embodiments of the presently disclosed invention contemplate methods for transcutaneous PDT to destroy a target cell in a mammalian subject comprising: administering to the subject a therapeutically effective amount of a photosensitizing agent or a photosensitizing agent delivery system or a prodrug, where the photosensitizing agent or photosensitizing agent delivery system or prodrug  
15 selectively binds to the target cell. This step is followed by irradiating at least a portion of the subject with light at a wavelength or waveband absorbed by the photosensitizing agent or if prodrug, by a prodrug product thereof, where the light is provided by a light source, and where the irradiation is at a relatively low fluence rate that results in the activation of the photosensitizing agent or prodrug product and the  
20 destruction of the target cell. This embodiment contemplates that the photosensitizing agent is cleared from non-target tissues of the subject prior to said irradiation.

#### BRIEF DESCRIPTION OF THE DRAWINGS

Figure 1A shows a diagram that demonstrates transcutaneous PDT using a focused laser diode light source.

25 Figure 1B shows PDT using a laser diode light source, where the light travels along the vessel wall to plaque with light scattering in plaque.

Figure 2 shows PDT using an optical fiber delivery of light from a laser diode light source (not shown).

Figure 3 shows PDT using an LED light source.

30 Figure 4 shows PDT using an optical diffuser attached to an optical fiber with delivery of light from a laser diode light source (not shown).

### DETAILED DESCRIPTION OF THE INVENTION

This invention provides methods and compositions for treating a target tissue or destroying or impairing a target cell or composition in a mammalian subject by the specific and selective binding to the target tissue, cell or composition of a photosensitizer agent. This method comprises irradiating at least a portion of the subject with light at a wavelength absorbed by said photosensitizing agent that under conditions of activation during photodynamic therapy using a relatively low fluence rate, but an overall high total fluence dose results in minimal collateral tissue damage.

Terms as used herein are based upon their art recognized meaning and from the present disclosure should be clearly understood by the ordinary skilled artisan. For sake of clarity, terms may also have particular meaning as would be clear from their use in context. For example, transcutaneous more specifically herein refers to the passage of light through unbroken tissue. Where the tissue layer is skin or dermis, transcutaneous includes transdermal and the light source is external to the outer skin layer. However, where transillumination refers herein to the passage of light through a tissue layer, such as the outer layer of a blood vessel, the light source is external to the blood vessel, but internal or implanted into the subject or patient.

Specifically, the present invention is based on the precise targeting of photosensitive agents or drugs and compounds to specific target antigens of a subject or patient and to the method of activation of targeted photosensitizer agents by subsequently administering to the subject light of a relatively low fluence rate over a prolonged period of time from a light source that is external to the target tissue in order to achieve maximal cytotoxicity or reduction of plaque or abnormal intima with minimal side effects or collateral tissue damage.

Further, as used herein "target cells" or "target tissues" are those cells or tissues, respectively that are intended to be impaired or destroyed by this treatment method. Target cells or target tissues take up the photosensitizing agent; then when sufficient radiation is applied, these cells or tissues are impaired or destroyed. Target cells are those cells in target tissues, which include, but are not limited to: vascular lesions, thick or thin neointimas, arterial plaques, neoplasms, vascular smooth muscle cells and the abnormal extracellular matrix of the site to be treated.. "Non-target cells" are all the cells of an intact animal which are not intended to be impaired or destroyed by the treatment method. These non-target cells include but are not limited to healthy



blood cells, and other normal tissue, not otherwise identified to be targeted.

"Destroy" is used to mean kill the desired target cell. "Impair" means to change the target cell in such a way as to interfere with its function. For example, North *et al.* observed that after exposure to light of benzoporphyrin derivatives ("BPD")-treated, virus-infected T cells, holes developed in the T cell membrane, which increased in size until the membrane completely decomposed (Blood Cells 18:129-40, 1992). Target cells are understood to be impaired or destroyed even if the target cells are ultimately disposed of by macrophages.

"Photosensitizing agent" is a chemical compound which homes to one or more types of selected target cells and, when contacted by radiation, absorbs the light, which results in impairment or destruction of the target cells. Virtually any chemical compound that homes to a selected target and absorbs light may be used in this invention. Preferably, the chemical compound is nontoxic to the animal to which it is administered or is capable of being formulated in a nontoxic composition. Preferably, the chemical compound in its photodegraded form is also nontoxic. A comprehensive listing of photosensitive chemicals may be found in Kreimer-Birnbaum, *Sem. Hematol.* 26:157-73, 1989. Photosensitive compounds include, but are not limited to, chlorins, bacteriochlorins, phthalocyanines, porphyrins, purpurins, merocyanines, psoralens, benzoporphyrin derivatives (BPD) and porfimer sodium and pro-drugs such as .delta.-aminolevulinic acid, which can produce drugs such as protoporphyrin. Other compounds include indocyanine green (ICG); methylene blue; toluidine blue; texaphyrins; and any other agent that absorbs light in a range of 500 nm -1100 nm.

"Radiation" as used herein includes all wave lengths. Preferably, the radiation wave length is selected to match the wave length(s) which excites the photosensitive compound. Even more preferably, the radiation wave length matches the excitation wave length of the photosensitive compound and has low absorption by the non-target cells and the rest of the intact animal, including blood proteins. For example, the preferred wave length for ICG is the range of 750-850 nm.

The radiation is further defined in this invention by its intensity, duration, and timing with respect to dosing with the photosensitive agent. The intensity or fluence rate must be sufficient for the radiation to penetrate skin and reach the target cells, target tissues or target compositions. The duration or total fluence dose must be sufficient to photoactivate enough photosensitive agent to act on the target cells. Both

intensity and duration must be limited to avoid overtreating the animal. Timing with respect to dosing with the photosensitive agent is important, because 1) the administered photosensitive agent requires some time to home in on target cells and 2) the blood level of many photosensitive agents decreases rapidly with time.

5 This invention provides a method of treating an animal, which includes, but is not limited to, humans and other mammals. The term "mammals" or "mammalian subject" also includes farm animals, such as cows, hogs and sheep, as well as pet or sport animals such as horses, dogs and cats.

10 By "intact animal" is meant that the whole, undivided animal is available to be exposed to radiation. No part of the animal is removed for separate radiation, in contrast with photophoresis, in which the animal's blood is circulated outside its body for exposure to radiation. The entire animal need not be exposed to radiation. Only a portion of the intact animal subject may or need be exposed to radiation.

15 "Transcutaneously" is used herein as meaning through the skin of an animal subject.

Briefly, the photosensitizing agent is generally administered to the animal before the animal is subjected to radiation.

20 Preferred photosensitizing agents include, but are not limited to, chlorins, bacteriochlorins, phthalocyanines, porphyrins, purpurins, merocyanines, psoralens and pro-drugs such as delta-aminolevulinic acid, which can produce drugs such as protoporphyrin. More preferred are: methylene blue; toluidine blue; texaphyrins; and any other agent that absorbs light in a range of 500 nm -1100 nm. Most preferred is indocyanine green (ICG) (for example, see: WO 92/00106 (Raven *et al.*); WO97/31582 (Abels *et al.*) and Devoisselle *et al.*, *SPIE* 2627:100-108, 1995).

25 The photosensitizing agent is administered locally or systemically. The photosensitizing agent is administered orally or by injection which may be intravenous, subcutaneous, intramuscular or intraperitoneal. The photosensitizing agent also can be administered enterally or topically via patches or implants.

30 The photosensitizing agent also can be conjugated to specific ligands reactive with a target, such as receptor-specific ligands or immunoglobulins or immunospecific portions of immunoglobulins, permitting them to be more concentrated in a desired target cell or microorganism. The photosensitizing agent may be further conjugated to a ligand-receptor binding pair, which includes, but is not

limited to: biotin-streptavidin; and antigen-antibody. This conjugation may permit lowering of the required dose level since the material is more selectively target and less is wasted in distribution into other tissues whose destruction must be avoided.

5 The photosensitizing agent can be administered in a dry formulation, such as pills, capsules, suppositories or patches. The photosensitizing agent also may be administered in a liquid formulation, either alone with water, or with pharmaceutically acceptable excipients, such as are disclosed in Remington's Pharmaceutical Sciences. The liquid formulation also can be a suspension or an emulsion. In particular, liposomal or lipophilic formulations are most desirable. If 10 suspensions or emulsions are utilized, suitable excipients include water, saline, dextrose, glycerol, and the like. These compositions may contain minor amounts of nontoxic auxiliary substances such as wetting or emulsifying agents, antioxidants, pH buffering agents, and the like.

15 The dose of photosensitizing agent will vary with the target cell(s) sought, the optimal blood level (see Example 1), the animal's weight and the timing of the radiation. Depending on the photosensitizing agent used, an equivalent optimal therapeutic level will have to be established. Preferably, the dose is calculated to obtain a blood level between about 0.001 and 100  $\mu\text{g/ml}$ . Preferably, the dose will obtain a blood level between about 0.01 and 10  $\mu\text{g/ml}$

20 This method comprises irradiating at least a portion of the subject with light at a wavelength or waveband absorbed by said photosensitizing agent that under conditions of activation during photodynamic therapy using a relatively low fluence rate, but also at an overall high total fluence dose resulting in minimal collateral tissue damage. It is contemplated that the optimal total fluence will be determined clinically 25 using a light dose escalation trial. It is further contemplated that the total fluence will preferably be in the range of 30 Joules to 25,000 Joules, and more preferably be in the range from 100 Joules to 20,000 Joules, and most preferably be in the range from 500 Joules to 10,000 Joules. The methods comprise irradiating at least a portion of the subject with light at a wavelength or waveband absorbed by said photosensitizing 30 agent that under conditions of activation during photodynamic therapy using a relatively low fluence rate, but an overall high total fluence dose resulting in minimal collateral normal tissue damage. What is meant by "relatively low fluence rate" is a fluence rate that is lower than that typically used and one that generally does not

result in significant damage to collateral or non-target tissues. Specifically, the intensity of radiation used to treat the target cell or target tissue is preferably between about 5 and 100 mW/cm.<sup>2</sup>. More preferably, the intensity of radiation is between about 10 and 75 mW/cm.<sup>2</sup>. Most preferably, the intensity of radiation is between about 15 and 50 mW/cm.<sup>2</sup>.

The duration of radiation exposure is preferably between about 30 minutes and 72 hours. More preferably, the duration of radiation exposure is between about 60 minutes and 48 hours. Most preferably, the duration of radiation exposure is between about 2 hours and 24 hours.

The total number of joules delivered to the treatment site is contemplated to lie between 30 J-25,000 J, more preferably between 100 J-20,000 J, and most preferably between 500 J-10,000 J.

Of course, clinical testing will be required to determine the optimal fluence rate and total fluence delivered to the treatment site.

While not wishing to be limited by a theory, the inventor proposes that a photosensitizer agent can be substantially and selectively photoactivated in the target cells and target tissues within a therapeutically reasonable period of time and without excess toxicity or collateral damage to non-target tissues. Thus, there appears to be a therapeutic window bounded by the photosensitizer agent dosage and radiation dosage. The formation of photodegradation products of a photosensitizer agent was used as an indicator of photoactivation. Photoactivation of a photosensitizer agent has been postulated to cause the formation of singlet oxygen, which has a cytotoxic effect.

Additionally, the present invention is drawn to a method for transcutaneous ultrasonic therapy of tumors in a mammalian subject or patient by first administering to the subject a therapeutically effective amount of a first conjugate comprising a first member of a ligand-receptor binding pair conjugated to an antibody or antibody fragment, wherein said antibody or antibody fragment selectively binds to a target antigen of thick or thin neointimas, arterial plaques, , vascular smooth muscle cells and/or the abnormal extracellular matrix of the site to be treated.; and simultaneously or subsequently administering to the subject a therapeutically effective amount of a second conjugate comprising a second member of the ligand-receptor binding pair conjugated to an ultrasonic sensitizing agent or ultrasonic sensitizing agent delivery

system or prodrug, wherein the first member binds to the second member of the ligand-receptor binding pair. These steps are followed by irradiating at least a portion of the subject with energy at a wavelength absorbed by said ultrasonic sensitizing agent or if ultrasonic sensitizing agent delivery system, by the product thereof, wherein said energy is provided by an energy source that is external to the subject; and wherein said ultrasound is at a relatively low intensity rate that results in the activation of said ultrasonic sensitizing agent or prodrug product.

While a preferred embodiment of the present invention is drawn to the use of light energy in a light or photodynamic therapy of tumors using light or photosensitizer agents, other forms of energy are within the scope of this invention and understandable by one of ordinary skill in the art. Such forms of energy include, but are not limited to: thermal; sonic; ultrasonic; chemical; photo or light; microwave; ionizing, such as: x-ray, and gamma ray; and electrical. For example, sonodynamically induced or activated agents include, but are not limited to: gallium-porphyrin complex (see: Yumita *et al.*, *Cancer Letters*, 112: 79-86, 1997); other porphyrin complexes, such as protoporphyrin and hematoporphyrin (see: Umemura *et al.*, *Ultrasonics Sonochemistry* 3: S187-S191, 1996); other cancer drugs, such as daunorubicin and adriamycin, used in the presence of ultrasound therapy (see: Yumita *et al.*, *Japan J. Hyperthermic Oncology*, 3(2): 175-182, 1987).

This invention further contemplates the use of an energy source, preferably a light source, that is external to the target tissue. The target tissues may include and may relate to the atherosclerotic lesions, restenotic lesions and the lesion antigens, *per se*. These target lesion antigens would be readily understood by one of ordinary skill in the art therefore to include but to not be limited to: tumor surface antigen; tumor endothelial antigen; non-tumor endothelial antigen; tumor vessel wall antigen; neointimal antigens; arterial plaque antigens; and vascular smooth muscle cell antigens.

The ordinary skilled artisan would be familiar with various ligand-receptor binding pairs, including those known and those currently yet to be discovered. Those known, include, but are not limited to the group consisting of: biotin-streptavidin; and antigen-antibody. This invention contemplates a preferred embodiment that includes the use of biotin-streptavidin as the ligand-receptor binding pair. However, the ordinary skilled artisan would readily understand from the present disclosure that

any ligand-receptor binding pair may be useful provided the ligand-receptor binding pair demonstrate a specificity for the binding by the ligand to the receptor and further provided that the ligand-receptor binding pair permit the creation of a first conjugate comprising a first member of the ligand-receptor binding pair conjugated to an antibody or antibody fragment, wherein said antibody or antibody fragment selectively binds to a target antigen of thick or thin neointimas, arterial plaques, , vascular smooth muscle cells and/or the abnormal extracellular matrix of the site to be treated; and further permit the creation of a second conjugate comprising a second member of the ligand-receptor binding pair conjugated to an energy sensitizing or photosensitizing agent or energy sensitizing or photosensitizing agent delivery system or prodrug, and further wherein the first member binds to the second member of the ligand-receptor binding pair.

A preferred embodiment of the present invention is drawn to a method where the photosensitizing agent delivery system includes a liposome delivery system consisting essentially of the photosensitizing agent, however the ordinary skilled artisan would readily understand from the present disclosure that other delivery systems may be used. A still further and preferred embodiment of the present invention contemplates the disclosed method where the photosensitizing agent delivery system utilizes both a liposome delivery system and a photosensitizing agent, where each is separately conjugated to a second member of the ligand-receptor binding pair, and where the first member binds to the second member of the ligand-receptor binding pair, and more preferably where the ligand-receptor binding pair is biotin-streptavidin. This embodiment further contemplates that the photosensitizing agent as well as the photosensitizing agent delivery system may both be specifically targeted through the selective binding to a target tissue antigen by the antibody or antibody fragment of the first member binding pair. Such dual targeting is envisioned to enhance the specificity of uptake and to increase the quantity of uptake.

Having now generally described the invention, the same will be more readily understood through reference to the following examples which are provided by way of illustration, and are not intended to be limiting of the present invention, unless specified.

EXAMPLE 1Transcutaneous Photodynamic Therapy of Vascular Lesions

Occlusive peripheral vascular disease, restenosis and other vascular lesions may be effectively treated by transcutaneous photodynamic therapy. Restenosis, the formation of a thick neointima due to the accumulation of proliferative smooth muscle cells and extracellular matrix at an injured site, is a frequent complication of surgical and percutaneous interventions for occlusive peripheral vascular disease. Restenosis occurs as a result of the natural reparative process and is proportional to the degree of injury inflicted upon the arterial wall. The current therapies include surgery, administration of anticoagulants such as Heparin®, vasoconstrictors such as Angiotensin II®, antiproliferative agents such as Angiopeptin®, Maphthopyran and Mycophenolate mofetil.

Since Heparin® has a high-binding capacity to basic fibroblast growth factor and is also a potent antiproliferative agent and Angiotensin II® is a polypeptide that induces vasoconstriction by binding to receptors on vascular smooth muscle cells, Heparin® or Angiotensin II® may be used to localize a photosensitizer agent to the vascular region in a mammalian subject to be treated. Alternatively, the photosensitizer may be conjugated to LDL, VLDL, or a similar agent that specifically binds to arterial plaques and/or vascular lesions.

Therefore, a photosensitizer agent is conjugated to a Heparin®, Angiotensin II®, LDL, VLDL, , or a similar agent which binds selectively to the thick neointimas, arterial plaques, neoplasms, vascular smooth muscle cells and/or the extracellular matrix of the site to be treated. Excess photosensitizer conjugates are eliminated from the body. One or more light sources are strategically placed or implanted near the tissue to be treated. Following a sufficient amount of time to permit clearing of the conjugates from the non-target tissues, the light sources are activated, irradiating the target tissue with a relatively low fluence rate, but high total fluence dose of light in the wavelength from about 750 nm to about 850 nm. The light may be applied internally or externally, with the external light source the preferred mode.

The specific dose of photosensitizer conjugate is that which results in a concentration of active ICG sufficient to obtain a blood level between about 0.001 and 100 µg/ml. and more preferably, a dose of between about 0.01 and 10 µg/ml. However, it is well within the skill of the ordinary skilled artisan to determine the

specific therapeutically effective dose using standard clinical practices and procedures.

Similarly, the specific fluence rate and total fluence dose may be routinely determined from the disclosure herein.

5            Additionally, the conjugate above could be further conjugated to an imaging agent such as technetium. Thus, the method could further comprise the steps of performing a nuclear medicine scan and imaging the vascular sites to be treated.

B.        A targeted antibody-photosensitizer conjugate (APC) is constructed which  
10        binds selectively to antigens mainly present on neointimas, arterial plaques and/or vascular smooth muscle cells. This ligand-receptor binding pair or APC is infused intravenously and is taken up in the neointimas, arterial plaques, neoplasms, vascular smooth muscle cells and/or the extracellular matrix. When unbound, APC is  
15        eliminated from the body. Internal or external light sources may be used to activate the targeted drug.

Any number of antigens may be selected, provided that the antigen is specific for the neointimas, arterial plaques, neoplasms, vascular smooth muscle cells and/or the abnormal extracellular matrix. Such antigens would be known to those skilled in  
20        the art. The selection of a specific photosensitizer agent may be made, provided the photosensitizer agent is activated by a light wavelength of from 500 nm to 1100 nm, and more preferably a wavelength of 650 nm, and most preferably by a wavelength of  
25        700 nm or greater. Such photosensitizer agents as provided in this disclosure are contemplated for use herein.

C.        The PDT light source is an externally positioned light source directed  
25        at the site to be treated. The light source may be a laser diode, light emitting diode or other electroluminescent device. The light source is angled and the light beam is focused to as to direct the light through the skin or membrane of the mammalian subject being treated in a direction lengthwise and parallel to the vessel wall. See  
30        Figures 1A and 1B.

Alternatively, the light source could comprise a laser diode coupled to  
an optical fiber which is then aimed at the vessel so as to direct the light along the  
length of the vessel. See Figure 2. The light source could also comprise a strip of  
light emitting diodes (LEDs) which are then arrayed on the skin or the membrane



overlying the site to be treated in the mammalian subject. See Figure 3. The light source could also comprise an optical fiber diffuser which is placed over the skin or the membrane overlying the site to be treated in the mammalian subject. See Figure 4.

5

D. As is apparent to one of ordinary skill in the art, the methods and compositions described above have various applications. For example, a group of small vessels in a mammalian subject may be treated by utilizing a patch composed of LEDs or a mat of woven optical fibers wherein the light source patch or mat is placed over the skin or the tissue overlying the site to be treated. Furthermore, the patch or mat could also contain pharmaceutical compositions or the photosensitizing agent which is then delivered by liposomal, transdermal or iontophoretic techniques. Additionally, vein grafts and artificial grafts could similarly be treated by the methods and compositions described above.

10  
15

This invention has been described by a direct description and by examples. As noted above, the examples are meant to be only examples and not to limit the invention in any meaningful way. Additionally, one having ordinary skill in the art to which this invention pertains in reviewing the specification and claims which follow would appreciate that there are equivalents to those claimed aspects of the invention. The inventors intend to encompass those equivalents within the reasonable scope of the claimed invention.

20

CLAIMS

1. A method for destroying or impairing target cells that comprise a lesion in the vascular system in a mammalian subject comprising:

5 administering to the subject a therapeutically effective amount of a photosensitizing agent, wherein said photosensitizing agent selectively binds to target cells of the lesion;

10 irradiating at least a portion of the subject with light at a wavelength absorbed by said photosensitizing agent, wherein said light is provided by a light source that is external to the intact body of the subject; and wherein said irradiation is at a relatively low fluence rate that results in the activation of said photosensitizing agent or said prodrug product

15 wherein said PDT drug is cleared from the skin and subcutaneous tissues of the subject prior to said irradiation.

2. A method for destroying or impairing target cells that comprise a lesion in the arterial vascular system in a mammalian subject comprising:

20 administering to the subject a therapeutically effective amount of a first conjugate comprising a first member of a ligand-receptor binding pair conjugated to an antibody or antibody fragment, wherein said antibody or antibody fragment selectively binds to a target cell or target tissue antigen;

25 administering to the subject a therapeutically effective amount of a second conjugate comprising a second member of the ligand-receptor binding pair conjugated to a photosensitizing agent or photosensitizing agent delivery system or prodrug, wherein the first member binds to the second member of the ligand-receptor binding pair;

30 irradiating at least a portion of the subject with light at a wavelength absorbed by said photosensitizing agent, wherein said light is provided by a light source that is external to the subject; and wherein said irradiation is at a relatively low fluence rate that results in the activation of said photosensitizing agent or prodrug product.

3. The method of claim 1 or 2, wherein said light source is selected from the group consisting of one or a plurality of: laser diodes, fiber lasers, LEDs, non-laser light source, cold cathode fluorescent tube, incandescent lights, halogen lights,

polymeric luminescent devices, other types of fluorescent lights, discharge lamps, and other electroluminescent devices.

4. The method of claim 1 or 2, wherein said light is directed through the skin in a direction parallel and lengthwise to the wall of a vascular vessel having the lesion.

5. The method of claim 3, wherein said laser diode is coupled to an optical fiber, and wherein said optical fiber directs said light lengthwise to the vessel wall having the lesion.

6. The method of claim 3, wherein said light emitting diode is a light emitting diode strip, and wherein said light emitting diode strip is placed over the skin overlying the lesion.

7. The method of claim 5, wherein said optical fiber diffuses said light when placed over the vessel wall having the lesion.

8. The method of claim 5, wherein said light source is a mat comprising a plurality of said optical fiber.

9. The method of claim 1 or 2, wherein said photosensitizing agent is selected from the group consisting of: indocyanine green; methylene blue; lutetium texaphyrin; toluidine blue; aminolevulinic acid (ALA) and any other agent that absorbs light in a range of 600 nm -1100 nm; and wherein said agent may be delivered as a delivery system or as a prodrug, the product thereof resulting in the photosensitize agent.

10. The method of claim 1 or 2, wherein said wavelength is from about 600 nm to about 1100 nm.

11. The method of claim 10, wherein said wavelength is greater than about 700 nm.

polymeric luminescent devices, other types of fluorescent lights, discharge lamps, and other electroluminescent devices.

4. The method of claim 1 or 2, wherein said light is directed through the skin in a direction parallel and lengthwise to the wall of a vascular vessel having the lesion.

5. The method of claim 3, wherein said laser diode is coupled to an optical fiber, and wherein said optical fiber directs said light lengthwise to the vessel wall having the lesion.

6. The method of claim 3, wherein said light emitting diode is a light emitting diode strip, and wherein said light emitting diode strip is placed over the skin overlying the lesion.

7. The method of claim 5, wherein said optical fiber diffuses said light when placed over the vessel wall having the lesion.

8. The method of claim 5, wherein said light source is a mat comprising a plurality of said optical fiber.

9. The method of claim 1 or 2, wherein said photosensitizing agent is selected from the group consisting of: indocyanine green; methylene blue; lutetium texaphyrin; toluidine blue; aminolevulinic acid (ALA) and any other agent that absorbs light in a range of 600 nm -1100 nm; and wherein said agent may be delivered as a delivery system or as a prodrug, the product thereof resulting in the photosensitize agent.

10. The method of claim 1 or 2, wherein said wavelength is from about 600 nm to about 1100 nm.

11. The method of claim 10, wherein said wavelength is greater than about 700 nm.

12. The method of claim 11, wherein said light results in a single photon absorption mode by the photosensitizing agent.

5 13. The method of claim 9, wherein a complex, comprising said photosensitizing agent conjugated to LDL or VLDL, localizes in the lesion.

14. The method of claim 13, wherein said complex is administered intravenously.

10 15. The method of claim 2, wherein said target tissue antigen is selected from the group consisting of: tumor surface antigen; tumor endothelial antigen; non-tumor endothelial antigen; and tumor vessel wall antigen.

15 16. The method of claim 2, wherein said ligand-receptor binding pair is selected from the group consisting of: biotin-streptavidin; chemokine-chemokine receptor; growth factor-growth factor receptor; and antigen-antibody.

20 17. The method of claim 1 or 2, wherein said photosensitizing agent delivery system comprises a liposome delivery system consisting essentially of the photosensitizing agent.

25 18. The method of claim 1 or 2, wherein said light source is pulse modulated to maximize depth of tissue penetration and minimize heat generation and power consumption.

19. The method of claim 1 or 2, wherein the total fluence of the light used for irradiating is between about 30 Joules/cm<sup>2</sup> and about 25,000 Joules/cm<sup>2</sup>.

30 20. The method of claim 1 or 2, wherein the total fluence of the light used for irradiating is between about 100 Joules/cm<sup>2</sup> and about 20,000 Joules/cm<sup>2</sup>.

21. The method of claim 1 or 2, wherein the total fluence of the light used for irradiating is between about 500 Joules/cm<sup>2</sup> and about 10,000 Joules/cm<sup>2</sup>.

5 22. An apparatus for transcutaneous photodynamic therapy of a lesion in the vascular system in a mammalian subject comprising a light source that is external to the subject and is selected from the group consisting of one or a plurality of: laser diodes; light emitting diodes; electroluminescent light sources; incandescent light sources; cold cathode fluorescent light sources; organic polymer light sources; or inorganic light sources.

10 23. The apparatus of claim 22, wherein said light source is at least one laser diode coupled to an optical fiber which directs said light lengthwise to the vessel wall having the lesion.

15 24. The apparatus of claim 23, wherein said diode is a light emitting diode strip, and wherein said light emitting diode strip may be placed over the skin overlying the lesion.

---

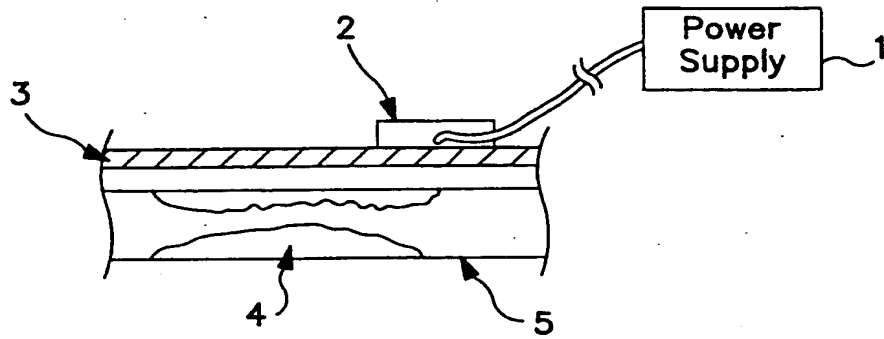

FIG. 1A

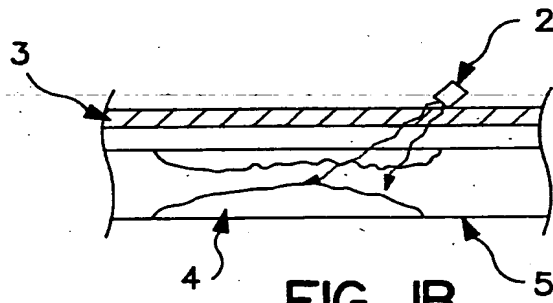

FIG. 1B

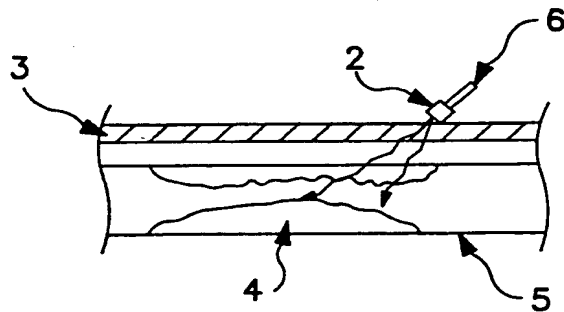

FIG. 2

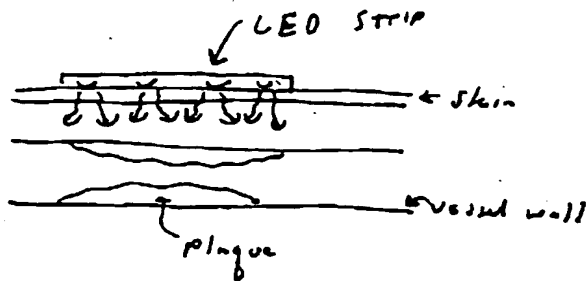

Figure 3

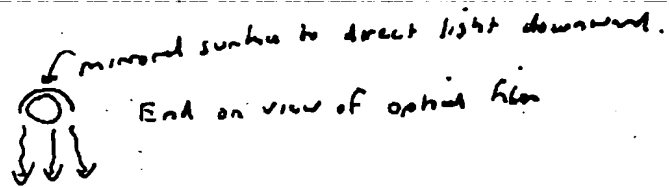
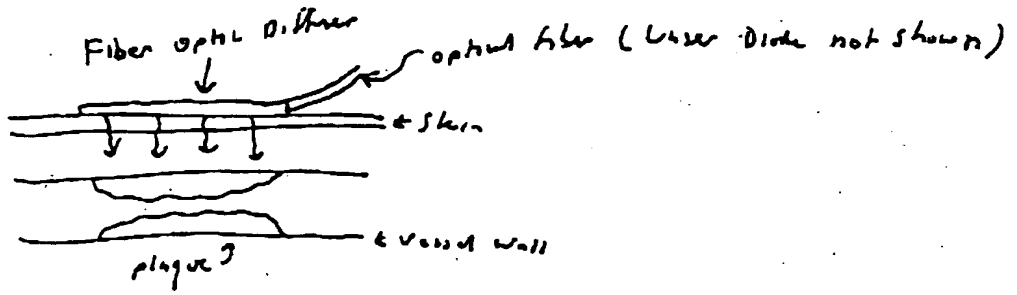

Figure 4



# INTERNATIONAL SEARCH REPORT

International Application No

PCT/US 00/00852

**A. CLASSIFICATION OF SUBJECT MATTER**  
IPC 7 A61K41/00

According to International Patent Classification (IPC) or to both national classification and IPC

**B. FIELDS SEARCHED**

Minimum documentation searched (classification system followed by classification symbols)  
IPC 7 A61K

Documentation searched other than minimum documentation to the extent that such documents are included in the fields searched

Electronic data base consulted during the international search (name of data base and, where practical, search terms used)

CHEM ABS Data, EMBASE, BIOSIS

**C. DOCUMENTS CONSIDERED TO BE RELEVANT**

Category *	Citation of document, with indication, where appropriate, of the relevant passages	Relevant to claim No.
A	US 5 829 448 A (DEES H CRAIG ET AL) 3 November 1998 (1998-11-03) cited in the application claims	22-24
X	US 5 705 518 A (LEVY JULIA G ET AL) 6 January 1998 (1998-01-06) cited in the application claims	1
X	EP 0 175 617 A (CYTOGEN CORP) 26 March 1986 (1986-03-26) claims	1, 15, 16
X	WO 95 32001 A (MOLTENI & C DEI FRATELLI ALITT ;NERI GIOVANNI (IT); RONCUCCI GABRI) 30 November 1995 (1995-11-30) claims	1-24
Y		1-24
	-/--	

Further documents are listed in the continuation of box C.

Patent family members are listed in annex.

\* Special categories of cited documents :

- "A" document defining the general state of the art which is not considered to be of particular relevance
- "E" earlier document but published on or after the international filing date
- "L" document which may throw doubts on priority claim(s) or which is cited to establish the publication date of another citation or other special reason (as specified)
- "O" document referring to an oral disclosure, use, exhibition or other means
- "P" document published prior to the international filing date but later than the priority date claimed

- "T" later document published after the international filing date or priority date and not in conflict with the application but cited to understand the principle or theory underlying the invention
- "X" document of particular relevance; the claimed invention cannot be considered novel or cannot be considered to involve an inventive step when the document is taken alone
- "Y" document of particular relevance; the claimed invention cannot be considered to involve an inventive step when the document is combined with one or more other such documents, such combination being obvious to a person skilled in the art.
- "&" document member of the same patent family

Date of the actual completion of the international search

27 June 2000

Date of mailing of the international search report

13/07/2000

Name and mailing address of the ISA

European Patent Office, P.B. 5818 Patentlaan 2  
NL - 2260 HV Rijswijk  
Tel. (+31-70) 340-2040, Tx. 31 651 epo nl.  
Fax: (+31-70) 340-3016

Authorized officer

Berte, M

INTERNATIONAL SEARCH REPORT

International Application No  
PCT/US 00/00852

C.(Continuation) DOCUMENTS CONSIDERED TO BE RELEVANT		
Category *	Citation of document, with indication, where appropriate, of the relevant passages	Relevant to claim No.
X	EP 0 407 122 A (REPLIGEN CORP) 9 January 1991 (1991-01-09) claims 1,12,19 ---	1-24
X	WO 97 46262 A (PHARMACYCLICS INC ;MAGDA DARREN (US); MODY TARAK D (US); UNIV TEXA) 11 December 1997 (1997-12-11) claims 1,29,32,43 ---	1,3-24
X	US 5 283 255 A (LEVY JULIA G ET AL) 1 February 1994 (1994-02-01) claims 1,18-22 ---	1-24
Y		1-24
X	US 5 171 749 A (LEVY JULIA G ET AL) 15 December 1992 (1992-12-15) claims; examples 14,19 ---	1-24
X	WO 93 11657 A (BISACCIA EMIL ;KLAINER ALBERT S (US)) 24 June 1993 (1993-06-24) claims ---	1-24
X	DATABASE CHEMABS 'Online! CHEMICAL ABSTRACTS SERVICE, COLUMBUS, OHIO, US; DARTSCH, P. C. ET AL: "Photodynamic therapy of vascular stenoses? Response of cultured human smooth muscle cells from non-atherosclerotic arteries and atheromatous plaques following treatment with photosensitizing porphyrins" retrieved from STN Database accession no. 115:67617 XP002141185 abstract & PROC. SPIE-INT. SOC. OPT. ENG. (1990), 1462(GER. SYMP. LASER ANGIOPLASTY, 2ND, 1989), 77-80 , ---	1-24
X	DATABASE CHEMABS 'Online! CHEMICAL ABSTRACTS SERVICE, COLUMBUS, OHIO, US; ADILI, FARZIN ET AL: "Local delivery of photosensitizing drugs in arteries: a novel approach to photodynamic therapy for the prevention of intimal hyperplasia" retrieved from STN Database accession no. 123:164182 XP002141186 abstract & PROC. SPIE-INT. SOC. OPT. ENG. (1995), 2395, 402-8 , -----	1-24

# INTERNATIONAL SEARCH REPORT

Information on patent family members

International Application No

PCT/US 00/00852

Patent document cited in search report	Publication date	Patent family member(s)	Publication date
US 5829448	A	03-11-1998	AU 716507 B 24-02-2000
			AU 5152898 A 22-05-1998
			BR 9712599 A 21-12-1999
			CA 2252783 A 07-05-1998
			CN 1226148 A 18-08-1999
			EP 0977592 A 09-02-2000
			NO 991492 A 31-05-1999
			US 6042603 A 28-03-2000
			WO 9818399 A 07-05-1998
			US 5998597 A 07-12-1999
US 5705518	A	06-01-1998	US 5770619 A 23-06-1998
			AT 189966 T 15-03-2000
			AU 679016 B 19-06-1997
			AU 5460094 A 22-06-1994
			CA 2149636 A 09-06-1994
			WO 9412239 A 09-06-1994
			DE 69327972 D 06-04-2000
			DE 947222 T 04-05-2000
			EP 0680365 A 08-11-1995
			EP 0947222 A 06-10-1999
			ES 2143539 T 16-05-2000
			FI 952436 A 05-07-1995
			HU 72037 A 28-03-1996
			JP 8505069 T 04-06-1996
			NO 952004 A 11-07-1995
PL 309033 A 18-09-1995			
ZA 9308710 A 30-06-1994			
EP 0175617	A	26-03-1986	US 4867973 A 19-09-1989
			AT 68974 T 15-11-1991
			AU 3016189 A 13-07-1989
			AU 583854 B 11-05-1989
			AU 4807185 A 08-04-1986
			CA 1326834 A 08-02-1994
			DE 3584559 A 05-12-1991
			DK 218386 A 11-07-1986
			GR 852217 A 14-01-1986
			JP 62500175 T 22-01-1987
			US 4950738 A 21-08-1990
			WO 8601720 A 27-03-1986
			US 5162512 A 10-11-1992
			US 5156840 A 20-10-1992
			US 5140104 A 18-08-1992
			ZA 8507064 A 27-05-1987
WO 9532001	A	30-11-1995	IT F1940095 A 23-11-1995
			AT 191852 T 15-05-2000
			AU 2566295 A 18-12-1995
			CA 2191195 A 30-11-1995
			DE 69516403 D 25-05-2000
			EP 0760679 A 12-03-1997
			US 5869051 A 09-02-1999
EP 0407122	A	09-01-1991	US 5112946 A 12-05-1992
			AT 143698 T 15-10-1996
			CA 2019086 A 06-01-1991
			DE 69028739 D 07-11-1996

# INTERNATIONAL SEARCH REPORT

information on patent family members

International Application No <b>PCT/US 00/00852</b>
--

Patent document cited in search report	Publication date	Patent family member(s)	Publication date
EP 0407122     A		DE 69028739 T	13-02-1997
		DK 407122 T	17-02-1997
		EP 0723015 A	24-07-1996
		ES 2092493 T	01-12-1996
		GR 3021658 T	28-02-1997
		JP 3063297 A	19-03-1991
WO 9746262     A	11-12-1997	AU 3226497 A	05-01-1998
		BR 9710685 A	11-01-2000
		CA 2257225 A	11-12-1997
		CN 1225591 A	11-08-1999
		EP 0954336 A	10-11-1999
		NO 985645 A	03-02-1999
US 5283255     A	01-02-1994	US 4883790 A	28-11-1989
		US 4920143 A	24-04-1990
		US 5171749 A	15-12-1992
		US 5399583 A	21-03-1995
		AT 104859 T	15-05-1994
		AU 618725 B	09-01-1992
		AU 1038888 A	21-07-1988
		CA 1333442 A	06-12-1994
		DE 3889231 D	01-06-1994
		DE 3889231 T	11-08-1994
		EP 0276121 A	27-07-1988
		ES 2055735 T	01-09-1994
		JP 1999536 C	08-12-1995
		JP 6008319 B	02-02-1994
		JP 63277700 A	15-11-1988
		JP 2835294 B	14-12-1998
		JP 7258262 A	09-10-1995
		MX 9203250 A	31-07-1992
		US 5095030 A	10-03-1992
		AT 127696 T	15-09-1995
		AU 638675 B	08-07-1993
		AU 3825889 A	08-02-1990
		DE 68924215 D	19-10-1995
		DE 68924215 T	15-02-1996
EP 0352076 A	24-01-1990		
EP 0641796 A	08-03-1995		
ES 2080745 T	16-02-1996		
GR 3017426 T	31-12-1995		
JP 2149519 A	08-06-1990		
JP 7080887 B	30-08-1995		
NO 179410 B	24-06-1996		
US 5171749     A	15-12-1992	US 4883790 A	28-11-1989
		US 4920143 A	24-04-1990
		US 5399583 A	21-03-1995
		US 5283255 A	01-02-1994
		AT 104859 T	15-05-1994
		AU 618725 B	09-01-1992
		AU 1038888 A	21-07-1988
		CA 1333442 A	06-12-1994
		DE 3889231 D	01-06-1994
		DE 3889231 T	11-08-1994
		EP 0276121 A	27-07-1988
		ES 2055735 T	01-09-1994

# INTERNATIONAL SEARCH REPORT

information on patent family members

International Application No

PCT/US 00/00852

Patent document cited in search report	Publication date	Patent family member(s)	Publication date
US 5171749    A		JP 1999536 C	08-12-1995
		JP 6008319 B	02-02-1994
		JP 63277700 A	15-11-1988
		JP 2835294 B	14-12-1998
		JP 7258262 A	09-10-1995
		MX 9203250 A	31-07-1992
		US 5095030 A	10-03-1992
		AT 127696 T	15-09-1995
		AU 638675 B	08-07-1993
		AU 3825889 A	08-02-1990
		DE 68924215 D	19-10-1995
		DE 68924215 T	15-02-1996
		EP 0352076 A	24-01-1990
		EP 0641796 A	08-03-1995
		ES 2080745 T	16-02-1996
		GR 3017426 T	31-12-1995
		JP 2149519 A	08-06-1990
		JP 7080887 B	30-08-1995
	NO 179410 B	24-06-1996	
WO 9311657    A	24-06-1993	US 5284869 A	08-02-1994
		AT 178757 T	15-04-1999
		AU 3328393 A	19-07-1993
		AU 3688497 A	18-12-1997
		CA 2117330 A	24-06-1993
		DE 69228952 D	20-05-1999
		DE 69228952 T	21-10-1999
		EP 0661920 A	12-07-1995
		ES 2131572 T	01-08-1999
		US 5426116 A	20-06-1995